

Bosch Rexroth Linear (Star)



At L&H, we pride ourselves in listening to our customers and providing them with a guideline to aid them in their linear motion guide program. Below is a listing of some concerns our customers have presented to us. Feel free to use this listing to review your linear guide program.

Common Problems with Linear Guides

Do you have problems with:

| | <u>Yes</u> | <u>No</u> |
|--|------------|-----------|
| 1. Delivery of standard product more than 24 hours | — | — |
| 2. Problems finding standard metric guides | — | — |
| 3. Getting to that one and only lube-port | — | — |
| 4. Short and frequent re-lubrication intervals | — | — |
| 5. Difficulty obtaining spare parts | — | — |
| 6. Getting competent application engineering help | — | — |
| 7. Seals that actually work and keep particles out of the bearing | — | — |
| 8. Bearings that can travel at high speeds (up to 10m/s) | — | — |
| 9. Finding corrosion resistant alternatives | — | — |
| 10. Finding a supplier for both your bushings and guide needs | — | — |
| 11. Getting rail cut to your required length within 24 hours | — | — |
| 12. Getting rails in a single section up to 6 meters | — | — |
| 13. Contamination problems in your bearings | — | — |
| 14. Quick turnaround on machined shafting | — | — |
| 15. Noisy Bearings | — | — |
| 16. Too much deflection in your system | — | — |
| 17. Bearing misalignment causing premature failure | — | — |
| 18. Determining the proper lube and lubrication interval | — | — |
| 19. Finding a dimensionally interchangeable unit for your current needs | — | — |
| 20. Buying from a supplier with expertise in linear motion, controls automation, and lubrication | — | — |

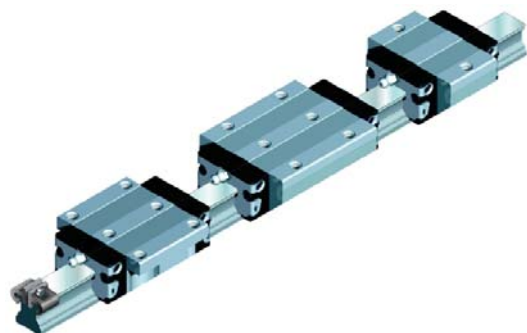

Livingston & Haven can provide the solution to all your Linear Guide problems

**For further information:
1-800-825-4969 or visit our website at www.Lhtech.com**

Bosch Rexroth Linear (Star)

Rexroth
Bosch Group

READY-TO-MOUNT LINEAR MOTION SYSTEMS IN A LARGE RANGE OF SELECTIONS

Linear Slides

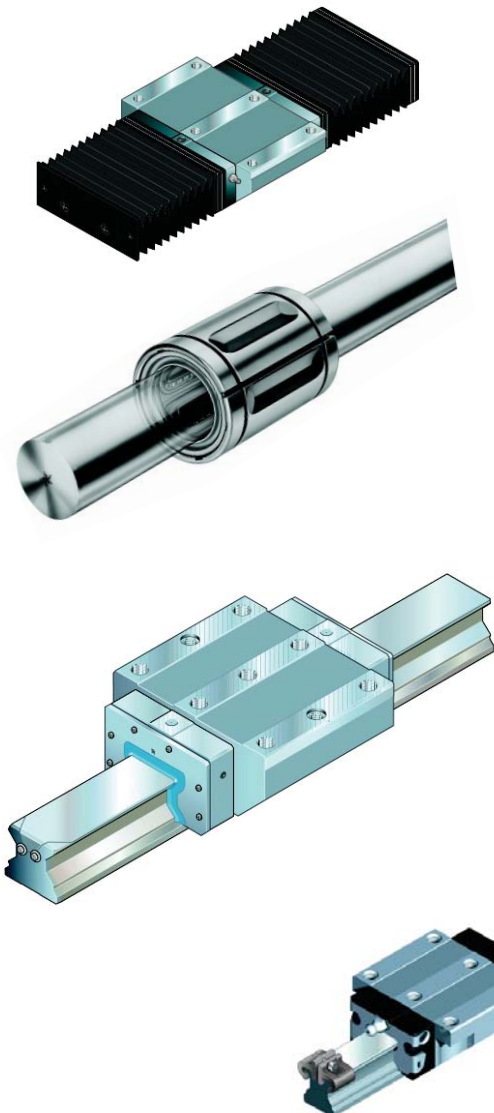

FEATURES

- Highest linear speeds in the industry- Up to 10 meters/second
- Longer lubrication intervals
- 24-hour delivery on cut to length Green light product (80% of needs)
- Local inventory in Charlotte
- Interchangeable blocks and rails
- Dimensionally interchangeable with THK, Thomson and other name brands
- Largest range of metric bushing styles in the world
- Self-aligning blocks and bushings

BENEFITS

- Increase production time, more parts, lower cost
- Less maintenance
- Less purchasing aggravation, Not waiting on key product
- Save costly air freight charges
- No need for matched sets, Easily replacement or upgrade of blocks
- Check the interchange program on our website www.Lhtech.com or call us and we will do the interchange for you.
- Those hard to find replacements just became easy to find
- Ability to mount to inaccurate surfaces, decreasing the need for expensive machining.

**For further information:
1-800-825-4969 or visit our
website at www.Lhtech.com**