



















































Section 2: Profiles

Technical Specifications

























												
		20x20	20x20 1S	20x20 2S	20x20 3S	20x20 2SA	20x20R	20x40	20x40 x40	20x60	30x30	30x30 1S
Moment of inertia	I_x [cm ⁴] (in ⁴)	0.67 (0.016)	0.84 (0.020)	0.84 (0.020)	0.74 (0.018)	0.70 (0.017)	0.58 (0.014)	4.62 (0.111)	6.0 (0.144)	14.20 (0.341)	2.75 (0.066)	3.12 (0.075)
	I_y [cm ⁴] (in ⁴)	0.67 (0.016)	0.76 (0.018)	0.68 (0.016)	0.67 (0.016)	0.70 (0.017)	0.58 (0.014)	1.20 (0.029)	6.0 (0.144)	1.70 (0.041)	2.75 (0.066)	3.48 (0.083)
Section modulus	W_x [cm ³] (in ³)	0.67 (0.041)	0.84 (0.051)	0.84 (0.051)	0.90 (0.055)	0.90 (0.055)	0.60 (0.037)	2.50 (0.153)	2.60 (0.159)	4.70 (0.288)	1.83 (0.112)	2.20 (0.134)
	W_y [cm ³] (in ³)	0.67 (0.041)	0.76 (0.046)	0.68 (0.041)	0.80 (0.049)	0.90 (0.055)	0.60 (0.037)	1.40 (0.086)	2.60 (0.159)	1.70 (0.104)	1.83 (0.112)	2.60 (0.159)
Profile surface	A [cm ²] (in ²)	1.60 (0.248)	1.92 (0.298)	1.83 (0.284)	1.70 (0.264)	1.80 (0.279)	1.60 (0.248)	2.90 (0.450)	4.14 (0.642)	3.48 (0.539)	3.10 (0.481)	3.70 (0.574)
Weight (Mass)	m [kg/m] (lbs/ft)	0.40 (0.269)	0.52 (0.349)	0.49 (0.329)	0.40 (0.269)	0.50 (0.336)	0.40 (0.269)	0.80 (0.538)	1.10 (0.740)	0.90 (0.605)	0.80 (0.538)	1.00 (0.672)
T-slot	[mm]											
Page		2-10	2-10	2-11	2-11	2-11	2-12	2-12	2-13	2-13	2-14	2-15

Section 2: Profiles





























													
30x30 2S	30x30 2SA	30x30 3S	30x30R	30x30°R	30x45°R	30x60°R	30x45	30x60	30x60 4S	30x60 x60	60x60 8S	40x40	40x40 1S
2.78 (0.067)	3.11 (0.075)	3.10 (0.074)	2.28 (0.055)	3.50 (0.084)	3.60 (0.087)	3.00 (0.072)	8.04 (0.193)	19.68 (0.473)	20.20 (0.485)	26.10 (0.627)	39.67 (0.952)	9.00 (0.219)	9.00 (0.219)
3.47 (0.083)	3.11 (0.075)	2.77 (0.067)	2.28 (0.055)	3.60 (0.087)	5.10 (0.123)	4.10 (0.099)	3.82 (0.092)	5.06 (0.122)	5.52 (0.132)	26.10 (0.627)	39.67 (0.952)	9.00 (0.219)	9.00 (0.219)
2.10 (0.128)	2.20 (0.134)	2.20 (0.134)	1.60 (0.098)	2.00 (0.123)	2.10 (0.129)	1.70 (0.104)	3.90 (0.239)	7.00 (0.429)	6.37 (0.411)	7.50 (0.459)	13.22 (0.807)	4.5 (0.275)	4.5 (0.275)
2.60 (0.159)	2.50 (0.153)	2.10 (0.128)	1.60 (0.098)	1.90 (0.116)	2.30 (0.141)	1.90 (0.116)	2.80 (0.172)	3.90 (0.239)	3.84 (0.234)	7.50 (0.459)	13.22 (0.807)	4.5 (0.275)	4.5 (0.275)
3.50 (0.543)	3.50 (0.543)	3.30 (0.512)	2.80 (0.434)	3.60 (0.558)	4.00 (0.620)	3.60 (0.558)	3.90 (0.605)	5.60 (0.868)	5.75 (0.891)	8.20 (1.271)	9.79 (1.517)	5.60 (0.776)	5.60 (0.776)
0.90 (0.605)	0.90 (0.605)	0.90 (0.605)	0.70 (0.471)	1.00 (0.673)	1.00 (0.673)	1.00 (0.673)	1.10 (0.740)	1.50 (1.009)	1.55 (1.042)	2.20 (1.480)	2.64 (1.774)	1.50 (1.008)	1.50 (1.008)
													
2-15	2-15	2-16	2-16	2-16	2-17	2-17	2-17	2-18	2-18	2-19	2-19	2-20	2-21

Section 2: Profiles

Technical Specifications















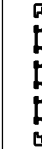
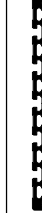







													
		40x40 2S	40x40 2SA	40x40 3S	40x 40R	40x40 HR	40x80	40x80 3SA	40x80 4S	40x80 x80	40x 120	40x 160	45x45
Moment of inertia	I_x [cm ⁴] (in ⁴)	10.34 (0.248)	9.71 (0.233)	9.07 (0.218)	7.20 (0.175)	8.10 (0.194)	63.40 (1.522)	67.81 (1.627)	65.17 (1.564)	96.60 (2.319)	203.20 (4.877)	466.70 (11.219)	11.00 (0.264)
	I_y [cm ⁴] (in ⁴)	9.08 (0.218)	9.71 (0.233)	9.70 (0.233)	7.20 (0.175)	7.60 (0.182)	17.30 (0.417)	18.99 (0.456)	19.05 (0.457)	96.60 (2.319)	27.80 (0.667)	37.20 (0.887)	11.00 (0.264)
Section modulus	W_x [cm ³] (in ³)	5.17 (0.315)	4.85 (0.295)	4.53 (0.276)	3.60 (0.219)	4.00 (0.243)	15.90 (0.974)	16.95 (1.034)	16.29 (0.994)	24.10 (1.469)	33.90 (2.075)	58.30 (3.551)	4.89 (0.298)
	W_y [cm ³] (in ³)	4.54 (0.277)	4.85 (0.295)	4.85 (0.235)	3.60 (0.219)	3.60 (0.219)	8.70 (0.532)	9.50 (0.580)	9.91 (0.605)	24.10 (1.469)	13.90 (0.851)	18.60 (1.137)	4.89 (0.298)
Profile surface	A [cm ²] (in ²)	5.96 (0.924)	5.36 (0.924)	5.79 (0.897)	5.00 (0.776)	5.50 (0.853)	9.90 (1.533)	10.56 (1.637)	10.39 (1.610)	15.40 (2.388)	15.50 (2.405)	20.50 (3.180)	5.70 (0.884)
Weight (Mass)	m [kg/m] (lbs/ft)	1.61 (1.083)	1.61 (1.083)	1.56 (1.050)	1.30 (0.873)	1.50 (1.009)	2.70 (1.815)	2.85 (1.918)	2.80 (1.882)	4.10 (2.757)	4.20 (2.824)	5.50 (3.696)	1.50 (1.009)
T-slot	[mm]												
Page		2-21	2-21	2-22	2-22	2-23	2-23	2-24	2-24	2-24	2-25	2-25	2-26

Section 2: Profiles













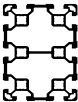
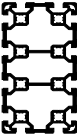





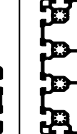
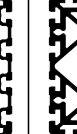
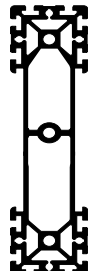

													
45x45H	45x45 1S	45x45 2S	45x45 2SA	45x45 3S	50x50T	45x45R	45x45HR	45x30°R	45x45°R	45x60°R	45x60H	45x90	45x90SL
13.83 (0.332)	11.75 (0.282)	11.54 (0.277)	11.80 (0.283)	11.79 (0.283)	15.14 (0.364)	8.56 (0.204)	11.02 (0.264)	12.70 (0.305)	13.40 (0.322)	11.40 (0.274)	37.20 (0.894)	81.84 (1.967)	73.36 (1.761)
13.83 (0.332)	12.06 (0.290)	11.38 (0.273)	11.80 (0.283)	11.68 (0.281)	15.16 (0.364)	8.56 (0.204)	10.73 (0.258)	15.20 (0.365)	21.40 (0.514)	17.00 (0.409)	22.67 (0.545)	23.40 (0.562)	18.09 (0.434)
6.15 (0.375)	5.20 (0.317)	5.10 (0.311)	5.20 (0.317)	5.20 (0.317)	6.70 (0.410)	5.00 (0.306)	4.40 (0.270)	5.00 (0.306)	5.20 (0.319)	4.40 (0.270)	12.40 (0.757)	18.18 (1.109)	16.30 (0.994)
6.15 (0.375)	5.30 (0.323)	5.00 (0.305)	5.20 (0.317)	5.20 (0.317)	7.70 (0.471)	5.00 (0.306)	4.70 (0.288)	5.30 (0.325)	6.40 (0.392)	5.20 (0.319)	10.08 (0.615)	10.40 (0.635)	8.04 (0.490)
7.50 (1.163)	5.90 (0.915)	5.80 (0.899)	5.90 (0.915)	5.90 (0.915)	4.60 (0.698)	4.90 (0.760)	6.60 (1.023)	6.90 (1.070)	7.60 (1.178)	6.80 (1.054)	11.00 (1.705)	11.20 (1.736)	9.04 (1.401)
2.00 (1.345)	1.60 (1.075)	1.60 (1.075)	1.60 (1.075)	1.60 (1.075)	1.20 (0.807)	1.30 (0.874)	1.80 (1.211)	1.80 (1.211)	2.00 (1.343)	1.80 (1.211)	2.90 (1.950)	3.00 (2.018)	2.44 (1.642)
													
2-27	2-27	2-28	2-28	2-29	2-29	2-30	2-30	2-31	2-31	2-31	2-32	2-33	2-34

Section 2: Profiles

Technical Specifications











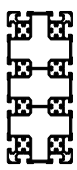













													
		45x90 2S	45x90 3VS	45x90H	45x90 x90	45x180 H	45x270 H	50x50	50x100	50x150	60x60	60x60H	60x90H
Moment of inertia	I_x [cm ⁴] (in ⁴)	85.61 (2.055)	87.20 (2.093)	124.62 (2.995)	151.13 (3.631)	766.67 (18.423)	3962.00 (95.207)	21.20 (0.512)	162.80 (3.924)	540.00 (12.979)	32.41 (0.779)	52.20 (1.254)	212.44 (5.105)
	I_y [cm ⁴] (in ⁴)	26.89 (0.645)	25.21 (0.605)	32.76 (0.787)	151.13 (3.631)	57.28 (1.376)	118.00 (2.836)	21.20 (0.512)	42.60 (1.019)	64.20 (1.543)	32.41 (0.779)	52.20 (1.254)	88.53 (2.127)
Section modulus	W_x [cm ³] (in ³)	38.05 (2.32)	38.80 (2.367)	27.69 (1.690)	29.10 (1.776)	85.19 (5.199)	300.20 (18.387)	8.50 (0.524)	32.60 (1.987)	72.00 (4.393)	10.80 (0.659)	17.40 (1.062)	47.21 (2.881)
	W_y [cm ³] (in ³)	5.98 (0.365)	5.60 (0.342)	14.56 (0.889)	29.10 (1.776)	25.46 (1.554)	61.50 (3.767)	8.50 (0.524)	17.00 (1.040)	25.70 (1.568)	10.80 (0.659)	17.40 (1.062)	29.51 (1.801)
Profile surface	A [cm ²] (in ²)	12.00 (1.86)	11.82 (1.832)	15.37 (2.382)	21.00 (3.255)	25.50 (3.953)	61.80 (9.579)	9.30 (1.442)	17.20 (2.668)	25.50 (3.952)	9.60 (1.488)	14.39 (2.230)	25.30 (3.922)
Weight (Mass)	m [kg/m] (lbs/ft)	3.24 (0.022)	3.2 (2.154)	4.15 (2.791)	5.67 (3.810)	6.90 (4.640)	16.70 (11.231)	2.50 (1.681)	4.60 (3.092)	6.90 (4.641)	2.60 (1.749)	3.89 (2.616)	6.80 (4.573)
T-slot	[mm]												
Page		2-34	2-35	2-36	2-37	2-38	2-39	2-40	2-41	2-42	2-43	2-44	2-45

Section 2: Profiles

											
80x80	80x80 6S	80x120	80x160	90x90 SL	90x90 4S	90x90 4VS	90x90	90x90H	90x180	90x180H	90x360H
132.10 (3.174)	140.90 (3.382)	389.30 (9.388)	850.80 (20.518)	130.24 (3.13)	227.4 (5.464)	220.86 (5.307)	211.10 (5.073)	299.80 (7.204)	1380.00 (33.161)	2138.30 (51.383)	14065.00 (337.982)
132.10 (3.174)	134.10 (3.218)	192.80 (4.649)	253.40 (6.111)	130.24 (3.13)	214.69 (5.159)	220.86 (5.307)	211.10 (5.073)	299.80 (7.204)	401.00 (9.636)	544.30 (13.080)	710.00 (17.061)
33.00 (2.020)	36.20 (2.209)	64.80 (3.947)	106.40 (6.481)	28.94 (1.766)	50.53 (3.084)	49.08 (2.995)	46.91 (2.863)	66.62 (4.065)	153.33 (9.357)	237.59 (14.499)	781.00 (46.869)
33.00 (2.020)	33.50 (2.044)	48.20 (2.950)	63.40 (3.880)	28.94 (1.766)	47.71 (2.911)	49.08 (2.995)	46.91 (2.863)	66.62 (4.065)	89.11 (5.438)	120.96 (7.381)	157.00 (9.616)
18.20 (2.824)	18.76 (2.908)	25.50 (3.956)	32.90 (5.104)	14.11 (2.187)	24.15 (3.743)	24.15 (3.743)	23.50 (3.643)	39.43 (6.112)	42.90 (6.650)	63.60 (9.858)	95.00 (14.725)
4.90 (3.295)	5.06 (3.400)	6.90 (5.983)	8.90 (5.983)	3.81 (2.560)	6.52 (4.381)	6.52 (4.381)	6.30 (4.237)	10.37 (6.974)	11.60 (7.801)	17.20 (11.567)	24.40 (16.409)
											
2-46	2-47	2-47	2-48	2-49	2-50	2-51	2-50	2-51	2-52	2-53	2-54





























Section 2: Profiles

Technical Specifications

														
		100x100	100X200	11x20	15x22.5	15x120	15x180	22.5x45	22.5x180	C30x45	30x30 WG30	30x45 WG30	30x30 WG40	30x45 WG40
Moment of inertia	I_x [cm ⁴] (in ⁴)	318.30 (7.639)	2133.10 (51.442)	0.52 (0.012)	0.81 (0.019)	110.4 (2.650)	303.50 (7.284)	711 (0.171)	581.01 (13.961)	10.33 (0.248)	2.57 (0.062)	7.00 (0.168)	2.48 (0.060)	6.98 (0.168)
	I_y [cm ⁴] (in ⁴)	318.30 (7.639)	602.10 (14.520)	0.13 (0.002)	0.34 (0.008)	2.16 (0.052)	3.14 (0.075)	2.91 (0.070)	11.80 (0.284)	5.60 (0.135)	3.01 (0.072)	4.25 (0.102)	2.92 (0.070)	4.11 (0.099)
Section modulus	W_x [cm ³] (in ³)	63.70 (3.896)	213.30 (12.992)	0.70 (0.043)	0.90 (0.055)	18.4 (11.224)	n.a.	3.16 (0.193)	64.56 (3.939)	4.23 (0.258)	1.64 (0.100)	4.30 (0.262)	1.57 (0.096)	4.33 (0.265)
	W_y [cm ³] (in ³)	63.70 (3.896)	120.40 (7.368)	0.30 (0.018)	0.60 (0.037)	2.74 (0.167)	n.a.	2.59 (0.158)	10.47 (0.639)	3.73 (0.228)	1.92 (0.118)	1.80 (0.110)	1.83 (0.112)	1.82 (0.111)
Profile surface	A [cm ²] (in ²)	29.90 (4.637)	54.00 (8.377)	1.00 (0.155)	1.20 (0.186)	9.00 (1.395)	11.64 (1.804)	4.60 (0.713)	21.60 (3.348)	4.38 (0.679)	3.19 (0.494)	4.52 (0.701)	3.16 (0.490)	4.49 (0.696)
Weight (Mass)	m [kg/m] (lbs/ft)	8.10 (5.449)	14.60 (9.815)	0.30 (0.202)	0.30 (0.202)	2.43 (1.635)	3.14 (2.113)	1.30 (0.874)	5.80 (3.901)	1.23 (0.827)	0.86 (0.579)	1.22 (0.820)	0.85 (0.574)	1.21 (0.814)
T-slot	[mm]													
Page		2-55	2-56	2-57	2-58	2-57	2-57	2-58	2-59	5-6 - 11-28	6-11	6-11	6-12	6-12

* Specialty profile. Not designed for structural support.

Section 2: Profiles

													
22.5x30F	EcoFlow Roller Profile	45x30 RP	45x45 RP	45x50 RP	45x75 SP2/B	15x30	45x45T	30x100 End	30x100 Center	LF6S	26x90	LF12S	LF20S
1.68 (0.040)	12.50 (0.300)	4.50 (0.108)	9.60 (0.231)	15.20 (0.365)	49.50 (1.189)	2.51 (0.060)	8.85 (0.213)	90.30 (2.170)	88.80 (2.134)	1.16 (0.028)	4.59 (0.110)	9.45 (0.227)	31.85 (0.765)
2.97 (0.071)	10.70 (0.257)	11.90 (0.286)	13.30 (0.320)	16.90 (0.406)	25.80 (0.620)	2.04 (0.049)	6.95 (0.167)	9.65 (0.232)	9.20 (0.221)	5.88 (0.141)	68.07 (1.636)	75.92 (1.824)	107.93 (2.594)
1.49 (0.091)	4.50 (0.276)	n. a.	3.80 (0.233)	5.30 (0.325)	12.10 (0.741)	*	3.18 (0.195)	18.00 (1.103)	17.80 (1.090)	1.08 (0.066)	3.65 (0.224)	7.02 (0.430)	23.95 (1.467)
1.98 (0.121)	4.50 (0.276)	n. a.	6.50 (0.398)	7.50 (0.459)	11.50 (0.704)	*	2.32 (0.142)	6.40 (0.392)	6.00 (0.368)	2.94 (0.180)	15.13 (0.927)	19.53 (1.196)	35.98 (2.204)
3.20 (0.496)	6.40 (0.992)	5.30 (0.822)	5.40 (0.837)	6.90 (1.070)	10.40 (1.612)	2.01 (0.312)	4.47 (0.693)	9.68 (1.500)	9.73 (1.508)	5.10 (0.791)	8.00 (1.240)	12.90 (2.000)	16.60 (2.573)
0.86 (0.579)	1.70 (1.143)	1.40 (0.942)	1.50 (1.009)	1.90 (1.278)	2.80 (1.883)	*	1.20 (0.807)	2.61 (1.755)	2.63 (1.769)	1.70 (1.143)	2.20 (1.480)	3.50 (2.354)	4.50 (3.026)
													
6-18	10-5	10-13	10-13	10-13	10-13	11-12	11-25	11-40	11-40	14-5 - 14-11	14-5 - 14-9	14-12 - 14-19	14-20 - 14-29

* Specialty profile. Not designed for structural support.







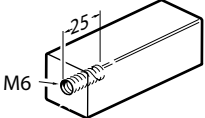

Section 2: Profiles

Rexroth offers a variety of end machining options for profiles, such as center bores tapped for a specific thread size, or through holes for use with bolt connectors. Most profiles have part numbers assigned for the popular machining options—just select the part number and state the desired length in millimeters.

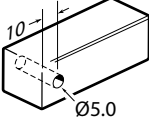
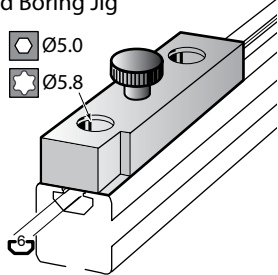
However, sometimes situations arise where you need a piece of profile with a through-hole or end tap, and you need it right away. Or you want the flexibility of keeping profiles on hand that you can cut to length and machine as the need arises. For situations like that, Rexroth offers a selection of thread taps, drill bits, and drilling

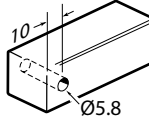
jigs specifically designed for common machining options.

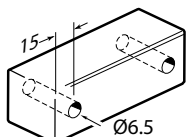

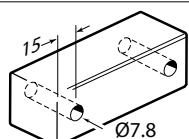
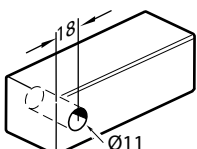
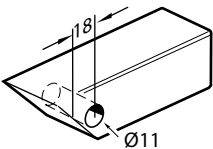
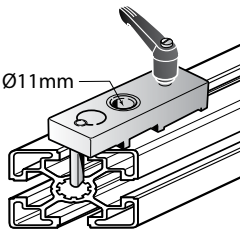

The following charts show popular end machining options, common applications, and the tools from Section 16 used to create them. Refer to the profile end machining options chart on the inside back cover fold-out for additional information.

	For Machine End Finish...	to Use Connector or Accessory,	Use Rexroth Specialty Tool:
6mm T-Slot	Tapped 6mm 	M6 Leveling Foot	Use a standard 6mm tap
	 Drilled: 5.0 mm through-hole 	5.0 mm diameter access hole for S6 x 16 self-tapping connection screw at end of profile for right-angle connections, or anywhere along the T-slot for T-connections.	6mm Drill and Boring Jig Page 15-3 
	 Drilled: 5.8 mm through-hole 	5.8 mm diameter access hole for S6 x 16 Torx-head self-tapping connection screw at end of profile for right-angle connections, or anywhere along the T-slot for T-connections	
8mm T-Slot	 Drilled: 6.5 mm through-hole 	6.5 mm diameter access hole for S8 x 25 self-tapping connection screw at end of profile for right-angle connections, or anywhere along the T-slot for T-connections.	
	 Drilled: 7.8 mm through-hole 	7.8 mm diameter access hole for S8 x 25 Torx-head self-tapping connection screw at end of profile for right-angle connections, or anywhere along the T-slot for T-connections.	
	Drilled: 11 mm through-hole 	<ul style="list-style-type: none"> • 30mm Bolt Connector Kit • 30mm Quick Connector/Rigid • 30x30 Multi-Angle Connector 	
	Drilled: 11 mm through-hole on 45° mitered profile 	<ul style="list-style-type: none"> • 30mm End-to-End Variable Angle Bolt Connector • 30mm End-to-Side Variable Angle Bolt Connector 	8mm Miter Drilling Jig Page 15-2 

Section 2: Profiles

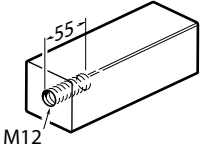
2

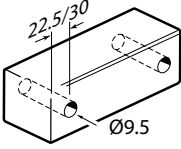
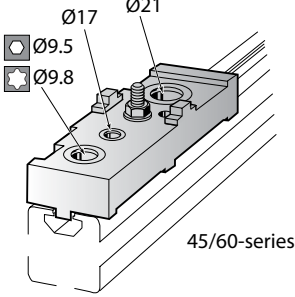
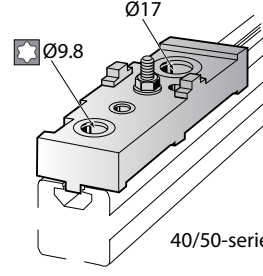
10mm T-Slot

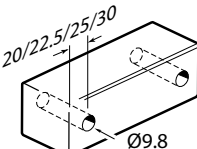
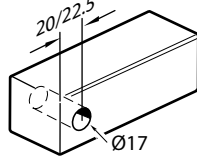
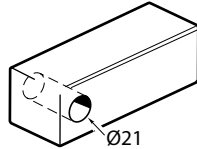
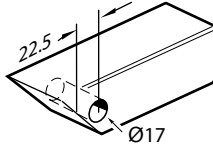
For Machine End Finish...	to Use Connector or Accessory,	Use Rexroth Specialty Tool:
Tapped 12mm 	<ul style="list-style-type: none"> • M12 Connection Screw • M12 Leveling Foot • 45mm Junction Connector • 45x45 Multi-Angle Connector • Heavy-Duty Caster • Pneumatic Fitting 	Use a standard 12mm tap
 Drilled: 9.5 mm through-hole 	9.5 mm diameter access hole for 45-/60-series profiles, for use with connection screws and other connectors and accessories.	10mm Drill and Boring Jigs Page 15-4 & 15-5  45/60-series  40/50-series
 Drilled: 9.8 mm through-hole 	9.8 mm diameter access hole for 45-/60-series or 40-/50-series profiles, for use with connection screws and other connectors and accessories.	
Drilled: 17 mm through-hole 	<ul style="list-style-type: none"> • Bolt Connector Kit • End-to-End Connector Kit • Multi-Angle Connector • Quick Connector/Rigid • Variable Angle Bolt Connector • Threaded Sleeve • 45° Angle Connector Kit 	
Drilled: 21 mm through-hole 	<ul style="list-style-type: none"> • Pneumatic Port 	
Drilled: 17 mm through-hole on 45° mitered profile 	<ul style="list-style-type: none"> • End-to-End Variable Angle Bolt Connectors • End-to-Side Variable Angle Bolt Connectors 	

Section 2: Profiles

20-Series Profiles

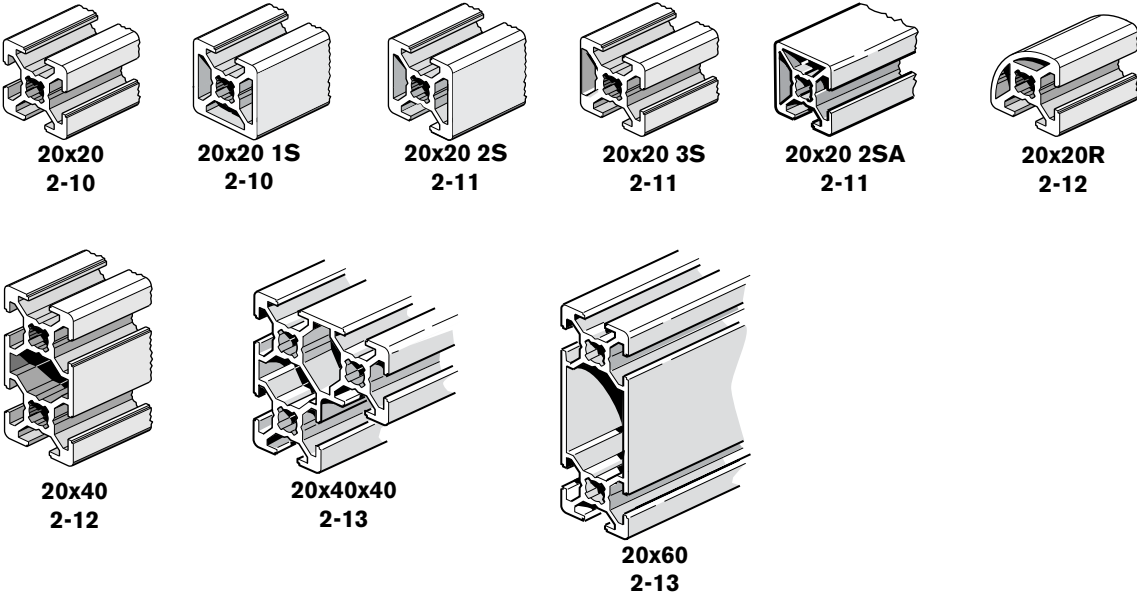

20x20 **GoTo**

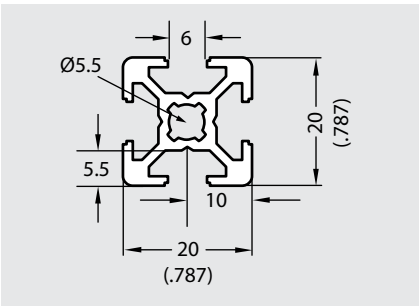

Features:

- Ideal for light-duty construction
- Has four 6mm T-slots

Non-Machined End Finish Options

	Part Number
Profile 20x20, pkg. of 20, 3000mm long	3 842 517 179 GoTo
Profile 20x20, single, 3000mm long	3 842 517 173 GoTo

Machined Options

Profile 20x20, -/-, specify length $\geq 30\text{mm} \leq 3000\text{mm}$

End Finish



Part Number

3 842 992 888/ __mm

Please contact your distributor for other machining options.

20x20 1S **Clean Room**

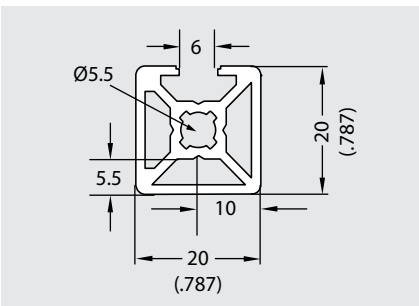

Features:

- Ideal for light-duty construction
- Closed T-slot adds neat, finished appearance

Non-Machined End Finish Options

	Part Number
Profile 20x20 1S, pkg. of 20, 3000mm long	3 842 536 475
Profile 20x20 1S, single, 3000mm long	3 842 536 476

Machined Options

Profile 20x20 1S, -/-, specify length $\geq 30\text{mm} \leq 3000\text{mm}$

End Finish



Part Number

3 842 993 421/ __mm

Please contact your distributor for other machining options.

GoTo boschrexroth-us.com/framing to get these in stock items **FAST** from your local distributor



Section 2: Profiles

2

20x20 2S 

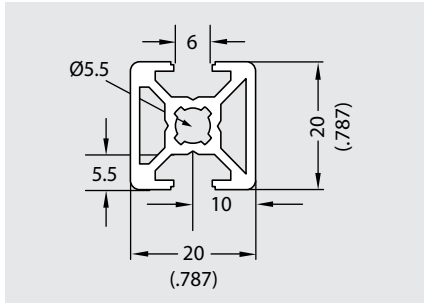

Features:

- Ideal for light-duty construction
- Has two 6mm T-slots

Non-Machined End Finish Options	Part Number
Profile 20x20 2S, pkg. of 20, 3000mm long	3 842 536 478
Profile 20x20 2S, single, 3000mm long	3 842 536 479

Machined Options	End Finish	Part Number
Profile 20x20 2S, -/-, specify length $\geq 30\text{mm} \leq 3000\text{mm}$	<input type="checkbox"/>	3 842 993 422/ __mm

Please contact your distributor for other machining options.

20x20 3S 

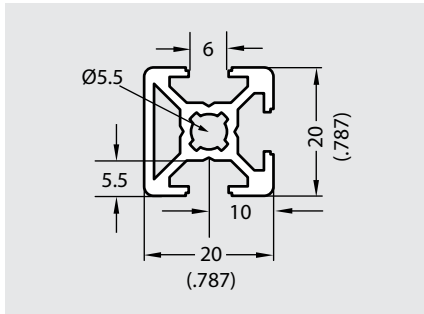

Features:

- Ideal for light-duty construction
- Closed T-slot adds neat, finished appearance
- Has three 6mm T-slots

Non-Machined End Finish Options	Part Number
Profile 20x20 3S, pkg. of 20, 3000mm long	3 842 517 180
Profile 20x20 3S, single, 3000mm long	3 842 517 174

Machined Options	End Finish	Part Number
Profile 20x20 3S, -/-, specify length $\geq 30\text{mm} \leq 3000\text{mm}$	<input type="checkbox"/>	3 842 992 889/ __mm

Please contact your distributor for other machining options.

20x20 2SA 

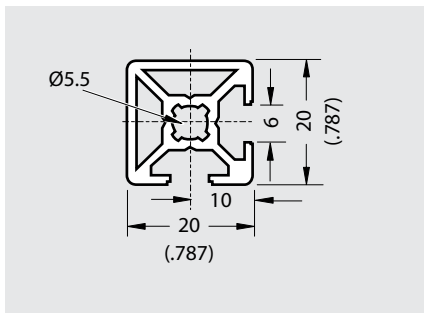

Features:

- Ideal for light-duty construction
- Closed T-slots add neat, finished appearance
- Has two adjacent 6mm T-slots



Non-Machined End Finish Options	Part Number
Profile 20x20 2SA, pkg. of 20, 3000mm long	3 842 519 658
Profile 20x20 2SA, single, 3000mm long	3 842 519 657

Machined Options	End Finish	Part Number
Profile 20x20 2SA, -/-, specify length $\geq 30\text{mm} \leq 3000\text{mm}$	<input type="checkbox"/>	3 842 992 924/ __mm

Please contact your distributor for other machining options.

Section 2: Profiles

20-Series Profiles

20x20R  

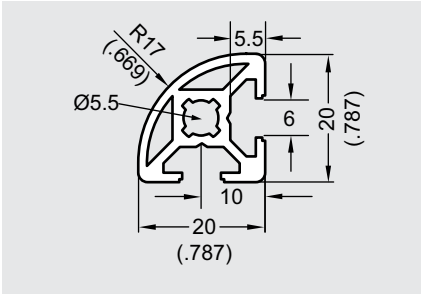

Features:

- Ideal for light-duty construction
- Radius corner adds neat, finished appearance
- Has two adjacent 6mm T-slots

Non-Machined End Finish Options	Part Number
Profile 20x20R, pkg. of 20, 3000mm long	3 842 517 183
Profile 20x20R, single, 3000mm long	3 842 517 177

Machined Options	End Finish	Part Number
Profile 20x20R, -/-, specify length $\geq 30\text{mm} \leq 3000\text{mm}$		3 842 992 890/ __mm

Please contact your distributor for other machining options.

20x40 

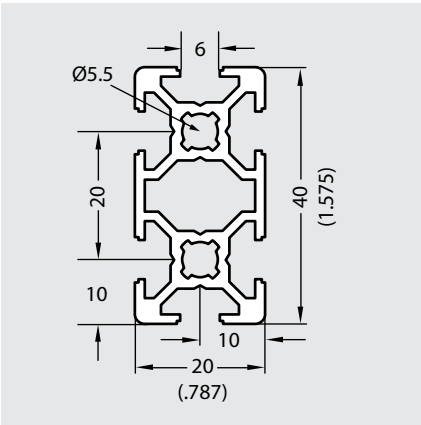

Features:

- Increased load-carrying capacity, ideal for shelving, tables, and safety guards
- Has six 6mm T-slots

Non-Machined End Finish Options	Part Number
Profile 20x40, pkg. of 24, 3000mm long	3 842 537 816
Profile 20x40, single, 3000mm long	3 842 517 178

Machined Options	End Finish	Part Number
Profile 20x40, -/-, specify length $\geq 30\text{mm} \leq 3000\text{mm}$		3 842 992 891/ __mm

Please contact your distributor for other machining options.

Section 2: Profiles

2

20x40x40 

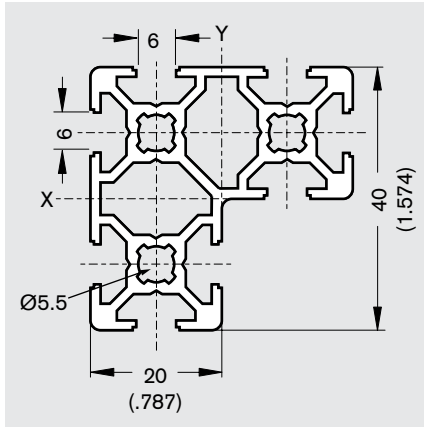

Features:

- L-shape allows for easy attachment of racks and shelves
- Use for enclosures and display cases
- Has eight 6mm T-slots

Non-Machined End Finish Options

Part Number

Profile 20x40x40, pkg. of 16, 3000mm long

3 842 537 818

Profile 20x40x40, single, 3000mm long

3 842 523 241

Machined Options

End Finish

Part Number

Profile 20x40x40, -/-, specify length $\geq 30\text{mm} \leq 3000\text{mm}$



3 842 992 991/ __mm

Please contact your distributor for other machining options.

20x60 

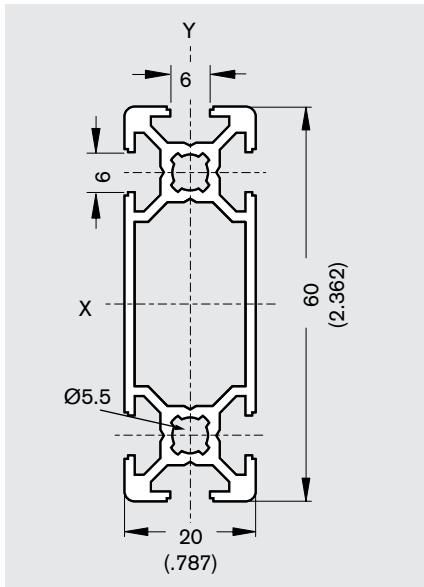

Features:

- Provides increased strength for light-duty machine bases and standard manual workstations
- Has six 6mm T-slots

Non-Machined End Finish Options

Part Number

Profile 20x60, pkg. of 16, 3000mm long

3 842 537 819

Profile 20x60, single, 3000mm long

3 842 523 239

Machined Options

End Finish

Part Number

Profile 20x60, -/-, specify length $\geq 30\text{mm} \leq 3000\text{mm}$



3 842 992 992/ __mm

Please contact your distributor for other machining options.

Section 2: Profiles

30-Series Profiles

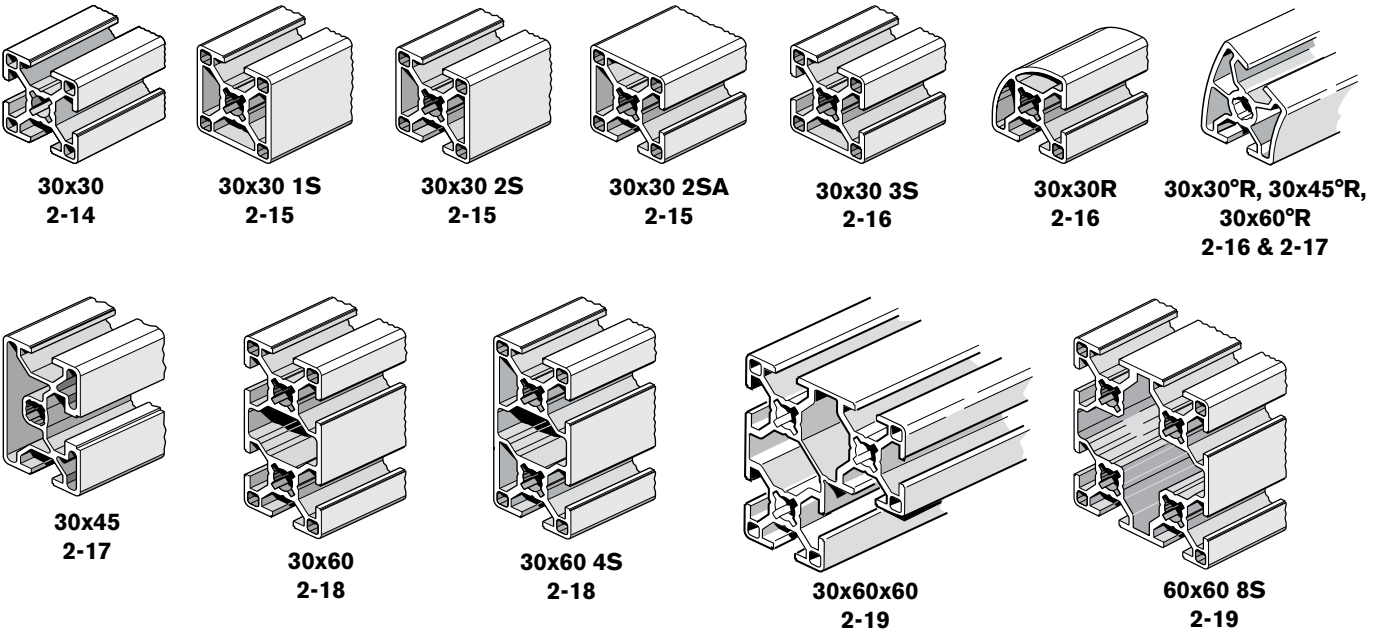

30x30 **Goto**

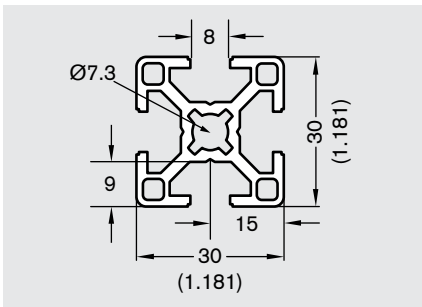

Features:

- Ideal for medium-duty, medium-stress construction, such as guarding, partitions, shelves, etc.
- Has four 8mm T-slots

Non-Machined End Finish Options

Profile 30x30, pkg. of 20, 6000mm long	3 842 501 574 <i>Goto</i>
Profile 30x30, single, 6000mm long	3 842 502 538 <i>Goto</i>

Part Number

3 842 501 574 <i>Goto</i>
3 842 502 538 <i>Goto</i>

Machined Options

Machined Options	End Finish	Part Number
Profile 30x30, -/-, specify length $\geq 30\text{mm} \leq 6000\text{mm}$		3 842 990 720/ __mm
Profile 30x30, M8/-, specify length $\geq 40\text{mm} \leq 6000\text{mm}$		3 842 990 721/ __mm
Profile 30x30, D11/-, specify length $\geq 30\text{mm} \leq 6000\text{mm}$		3 842 990 722/ __mm
Profile 30x30, M8/M8, specify length $\geq 80\text{mm} \leq 6000\text{mm}$		3 842 990 723/ __mm
Profile 30x30, M8/D11, specify length $\geq 70\text{mm} \leq 6000\text{mm}$		3 842 990 724/ __mm
Profile 30x30, D11/D11, specify length $\geq 60\text{mm} \leq 6000\text{mm}$		3 842 990 725/ __mm
Profile 30x30, D11/D11VS, specify length $\geq 60\text{mm} \leq 6000\text{mm}$		3 842 990 726/ __mm
Profile 30x30, D7.8/D7.8, specify length $\geq 60\text{mm} \leq 6000\text{mm}$		3 842 992 965/ __mm

Please contact your distributor for other machining options.

Goto boschrexroth-us.com/framing to get these in stock items **FAST** from your local distributor

Section 2: Profiles

2

30x30 1S 

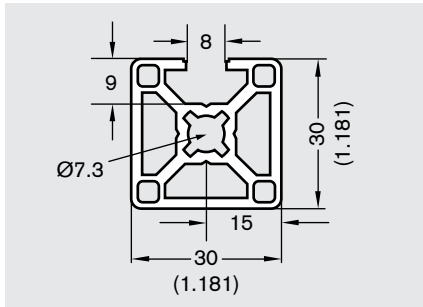

Features:

- Ideal for medium-duty construction
- Closed T-slots provide neat, finished appearance
- Has one 8mm T-slot

Non-Machined End Finish Options

	Part Number
Profile 30x30 1S, pkg. of 20, 5600mm long	3 842 506 948
Profile 30x30 1S, single, 5600mm long	3 842 506 952

Machined Options

	End Finish	Part Number
Profile 30x30 1S, -/-, specify length $\geq 30\text{mm} \leq 5600\text{mm}$	<input type="checkbox"/>	3 842 992 397/ __mm

Please contact your distributor for other machining options.

30x30 2S 

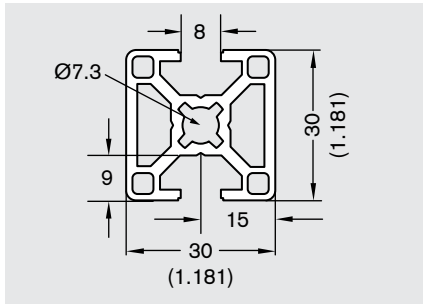

Features:

- Ideal for medium-duty construction
- Two closed T-slots provide neat, finished appearance
- Has two 8mm T-slots

Non-Machined End Finish Options

	Part Number
Profile 30x30 2S, pkg. of 20, 5600mm long	3 842 506 950
Profile 30x30 2S, single, 5600mm long	3 842 506 954

Machined Options

	End Finish	Part Number
Profile 30x30 2S, -/-, specify length $\geq 30\text{mm} \leq 5600\text{mm}$	<input type="checkbox"/>	3 842 992 399/ __mm

Please contact your distributor for other machining options.

30x30 2SA 

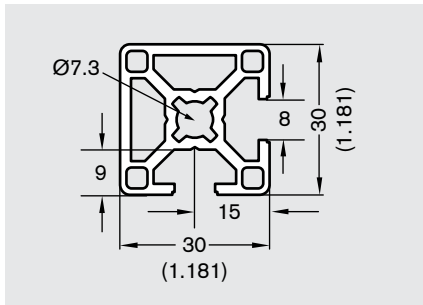

Features:

- Ideal for medium-duty construction
- Two adjacent closed T-slots provide neat, finished appearance
- Has two adjacent 8mm T-slots

Non-Machined End Finish Options

	Part Number
Profile 30x30 2SA, pkg. of 20, 5600mm long	3 842 506 949
Profile 30x30 2SA, single, 5600mm long	3 842 506 953

Machined Options

	End Finish	Part Number
Profile 30x30 2SA, -/-, specify length $\geq 30\text{mm} \leq 5600\text{mm}$	<input type="checkbox"/>	3 842 992 398/ __mm

Please contact your distributor for other machining options.

Section 2: Profiles

30-Series Profiles

30x30 3S

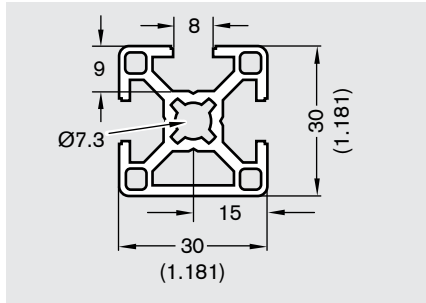

Features:

- Ideal for medium-duty construction
- Closed T-slot provides neat, finished appearance
- Has three 8mm T-slots

Non-Machined End Finish Options	Part Number
Profile 30x30 3S, pkg. of 20, 5600mm long	3 842 506 951
Profile 30x30 3S, single, 5600mm long	3 842 506 955

Machined Options	End Finish	Part Number
Profile 30x30 3S, -/-, specify length $\geq 30\text{mm} \leq 5600\text{mm}$	<input type="text"/>	3 842 992 400/ __mm

Please contact your distributor for other machining options.

30x30R

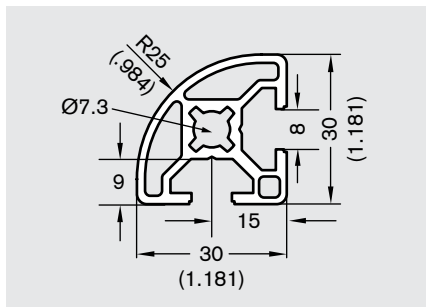

Features:

- Ideal for medium-duty construction
- Radius corner provides neat, finished appearance
- Has two adjacent 8mm T-slots

Non-Machined End Finish Options	Part Number
Profile 30x30R, pkg. of 20, 5600mm long	3 842 517 198
Profile 30x30R, single, 5600mm long	3 842 517 197

Machined Options	End Finish	Part Number
Profile 30x30R, -/-, specify length $\geq 30\text{mm} \leq 5600\text{mm}$	<input type="text"/>	3 842 992 896/ __mm

Please contact your distributor for other machining options.

30x30°R

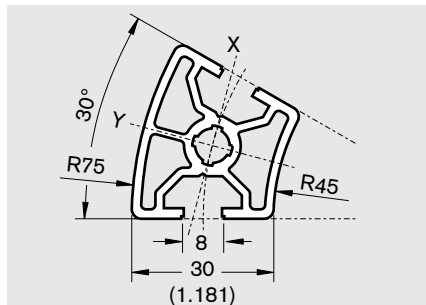

Features:

- Provides high-tech appearance
- Curved surfaces ideal for following machine or space contours
- Has two 8mm T-slots

Non-Machined End Finish Options	Part Number
Profile 30x30°R, pkg. of 20, 5600mm long	3 842 524 031
Profile 30x30°R, single, 5600mm long	3 842 524 030

Machined Options	End Finish	Part Number
Profile 30x30°R, -/-, specify length $\geq 30\text{mm} \leq 5600\text{mm}$	<input type="text"/>	3 842 993 010/ __mm

Please contact your distributor for other machining options.

Section 2: Profiles

2

30x45°R  

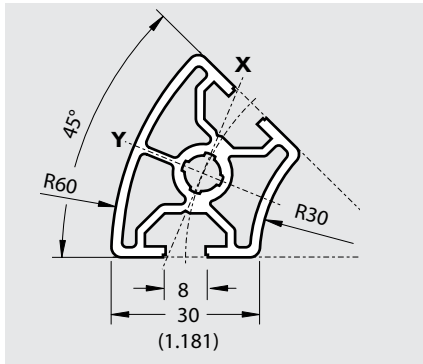

Features:

- Provides high-tech appearance
- Curved surfaces ideal for following machine or space contours
- Has two 8mm T-slots

Non-Machined End Finish Options

Non-Machined End Finish Options	Part Number
Profile 30x45°R, pkg. of 20, 5600mm long	3 842 524 034
Profile 30x45°R, single, 5600mm long	3 842 524 033

Machined Options

Profile 30x45°R, -/-, specify length $\geq 30\text{mm} \leq 5600\text{mm}$



End Finish



Part Number

3 842 993 011/ __mm

Please contact your distributor for other machining options.

30x60°R  

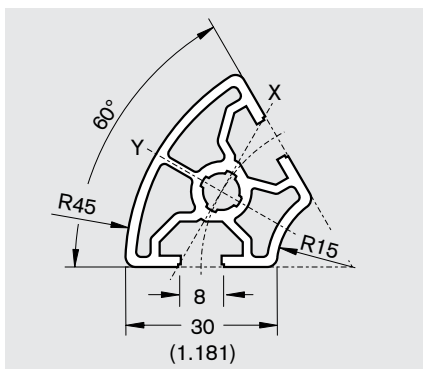

Features:

- Provides high-tech appearance
- Curved surfaces ideal for following machine or space contours
- Has two 8mm T-slots

Non-Machined End Finish Options

Non-Machined End Finish Options	Part Number
Profile 30x60°R, pkg. of 20, 5600mm long	3 842 524 037
Profile 30x60°R, single, 5600mm long	3 842 524 036

Machined Options

Profile 30x60°R, -/-, specify length $\geq 30\text{mm} \leq 5600\text{mm}$

End Finish



Part Number

3 842 993 012/ __mm

Please contact your distributor for other machining options.

30x45  

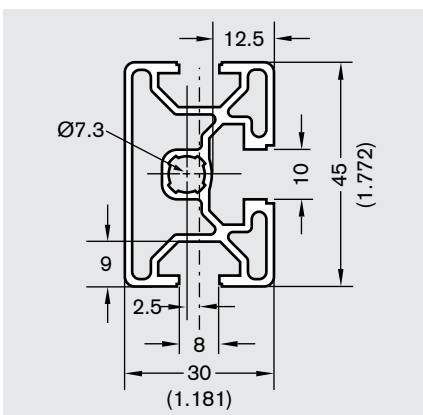

Features:

- Ideal for intermediate connection between 8mm and 10mm T-slotted profiles
- Has two 8mm T-slots and one 10mm T-slot

Non-Machined End Finish Options

Non-Machined End Finish Options	Part Number
Profile 30x45, pkg. of 18, 5600mm long	3 842 511 704
Profile 30x45, single, 5600mm long	3 842 511 703

Machined Options

Profile 30x45, -/-, specify length $\geq 30\text{mm} \leq 5600\text{mm}$

Profile 30x45, M8/-, specify length $\geq 40\text{mm} \leq 5600\text{mm}$

End Finish



Part Number

3 842 992 430/ __mm

3 842 992 431/ __mm

Please contact your distributor for other machining options.

Section 2: Profiles

30-Series Profiles

30x60 **GoTo**

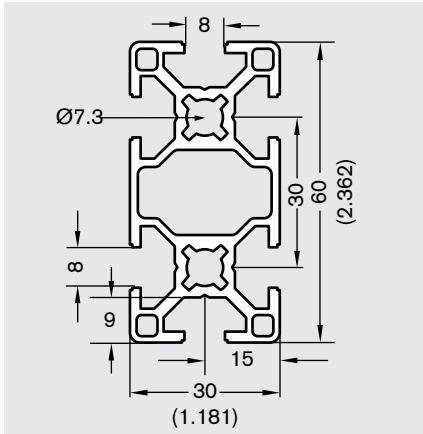

Features:

- One of the strongest profiles with 8mm T-slots
- Has six 8mm T-slots

Non-Machined End Finish Options









Part Number

Profile 30x60, pkg. of 10, 5600mm long	3 842 512 603 GoTo
Profile 30x60, single, 5600mm long	3 842 512 930 GoTo

Machined Options

End Finish

Part Number

Profile 30x60, -/-, specify length $\geq 30\text{mm} \leq 5600\text{mm}$		3 842 992 457/ __mm
Profile 30x60, M8/-, specify length $\geq 40\text{mm} \leq 5600\text{mm}$		3 842 992 458/ __mm
Profile 30x60, D11/-, specify length $\geq 30\text{mm} \leq 5600\text{mm}$		3 842 992 459/ __mm
Profile 30x60, D11VS/-, specify length $\geq 30\text{mm} \leq 5600\text{mm}$		3 842 992 461/ __mm
Profile 30x60, M8/M8, specify length $\geq 80\text{mm} \leq 5600\text{mm}$		3 842 992 926/ __mm
Profile 30x60, D11/D11, specify length $\geq 60\text{mm} \leq 5600\text{mm}$		3 842 992 460/ __mm
Profile 30x60, D11VS/D11VS, specify length $\geq 60\text{mm} \leq 5600\text{mm}$		3 842 992 462/ __mm
Profile 30x60, D11VS/D11, specify length $\geq 60\text{mm} \leq 5600\text{mm}$		3 842 992 463/ __mm

Please contact your distributor for other machining options.

30x60 4S

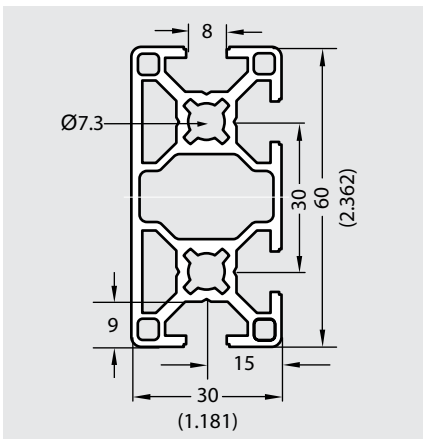

Features:

- Ideal for medium-duty construction
- Use for enclosures and display cases
- Has four 8mm T-slots

Non-Machined End Finish Options

Part Number

Profile 30x60 4S, pkg. of 10, 6000mm long	3 842 536 472
Profile 30x60 4S, single, 6000mm long	3 842 536 473

Machined Options

End Finish

Part Number

Profile 30x60 4S, -/-, specify length $\geq 40\text{mm} \leq 6000\text{mm}$		3 842 993 420/ __mm
-----------------------------------------------------------------------------	-------------------------------------------------------------------------------------	----------------------------

Please contact your distributor for other machining options.

GoTo boschrexroth-us.com/framing to get these in stock items **FAST** from your local distributor



Section 2: Profiles

2

30x60x60 

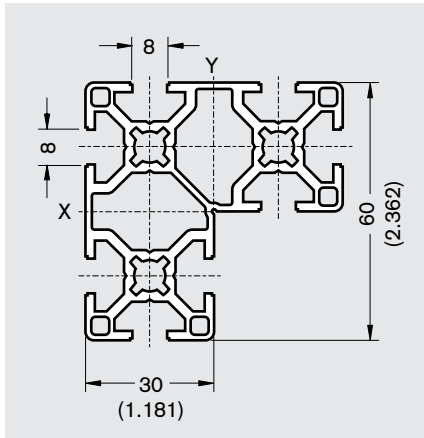

Features:

- L-shape allows for easy attachment of racks and shelves
- Use for enclosures and display cases
- Has eight 8mm T-slots

Non-Machined End Finish Options	Part Number
Profile 30x60x60, pkg. of 20, 5600mm long	3 842 524 049
Profile 30x60x60, single, 5600mm long	3 842 524 048

Machined Options	End Finish	Part Number
Profile 30x60x60, -/-, specify length $\geq 30\text{mm} \leq 5600\text{mm}$	<input type="checkbox"/>	3 842 993 016/ __mm

Please contact your distributor for other machining options.



60x60 8S 

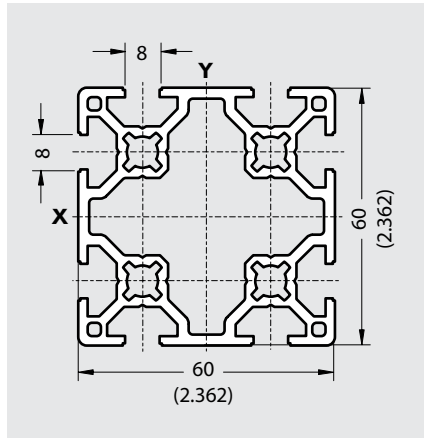

Features:

- Ideal for heavy applications where added strength and additional T-slots are required
- Has eight 8mm T-slots

Non-Machined End Finish Options	Part Number
Profile 60x60 8S, pkg. of 20, 6000mm long	3 842 535 176
Profile 60x60 8S, single, 6000mm long	3 842 535 175

Machined Options	End Finish	Part Number
Profile 60x60 8S, -/-, specify length $\geq 40\text{mm} \leq 6000\text{mm}$	<input type="checkbox"/>	3 842 993 033/ __mm

Please contact your distributor for other machining options.

Section 2: Profiles

40-Series Profiles

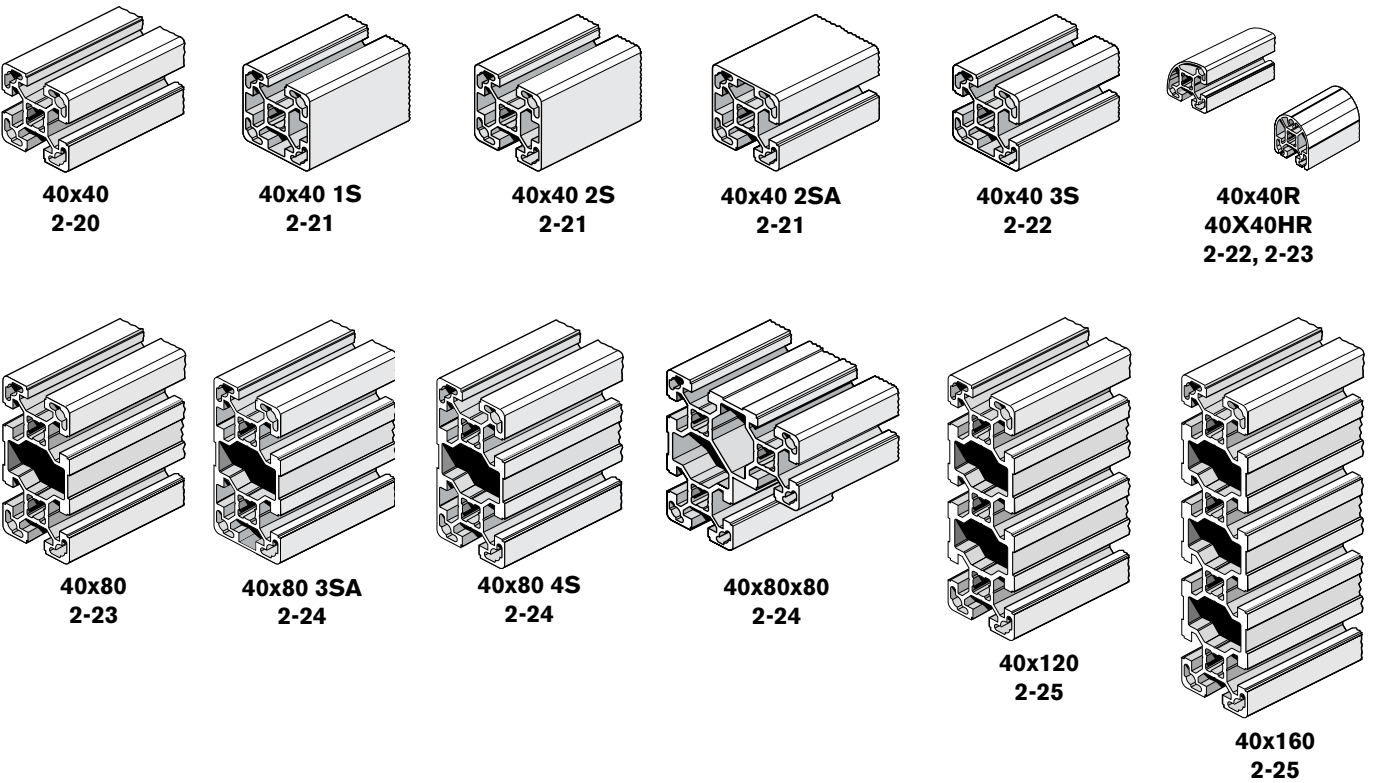

40x40 **GoTo**

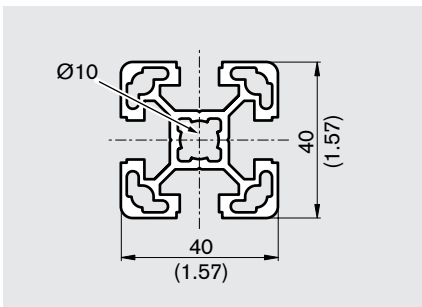

Features:

- Ideal for medium-duty, medium-stress construction, such as guarding, partitions, shelves, etc.
- Has four 10mm T-slots

Non-Machined End Finish Options

	Part Number
Profile 40x40, pkg. of 20, 6000mm long	3 842 529 339 <i>GoTo</i>
Profile 40x40, single, 6000mm long	3 842 529 340 <i>GoTo</i>

Machined Options

	End Finish	Part Number
Profile 40x40, -/-, specify length $\geq 30\text{mm} \leq 6000\text{mm}$		3 842 993 120/ __mm
Profile 40x40, M12/-, specify length $\geq 55\text{mm} \leq 6000\text{mm}$		3 842 993 121/ __mm
Profile 40x40, D17/-, specify length $\geq 40\text{mm} \leq 6000\text{mm}$		3 842 993 124/ __mm
Profile 40x40, M12/M12, specify length $\geq 110\text{mm} \leq 6000\text{mm}$		3 842 993 122/ __mm
Profile 40x40, M12/D17, specify length $\geq 90\text{mm} \leq 6000\text{mm}$		3 842 993 123/ __mm
Profile 40x40, D17/D17, specify length $\geq 80\text{mm} \leq 6000\text{mm}$		3 842 993 125/ __mm
Profile 40x40, D17/D17VS, specify length $\geq 80\text{mm} \leq 6000\text{mm}$		3 842 993 126/ __mm
Profile 40x40, D9.8/D9.8, specify length $\geq 80\text{mm} \leq 6000\text{mm}$		3 842 993 129/ __mm

Please contact your distributor for other machining options.

GoTo boschrexroth-us.com/framing to get these in stock items **FAST** from your local distributor

Section 2: Profiles

2

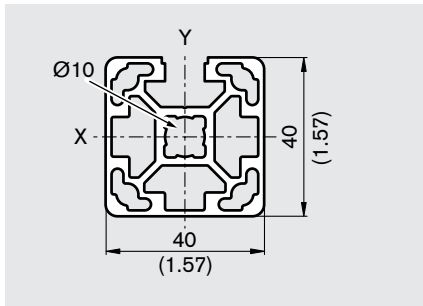

40x40 1S 



Features:

- Ideal for medium-duty construction
- Closed T-slots provide neat, finished appearance
- Has one 10mm T-slot

Non-Machined End Finish Options	Part Number
Profile 40x40 1S, pkg. of 20, 6000mm long	3 842 529 361
Profile 40x40 1S, single, 6000mm long	3 842 529 362

Machined Options	End Finish	Part Number
Profile 40x40 1S, -/-, specify length $\geq 30\text{mm} \leq 6000\text{mm}$		3 842 993 185/ __mm
Profile 40x40 1S, M12/M12, specify length $\geq 110\text{mm} \leq 6000\text{mm}$		3 842 993 186/ __mm

Please contact your distributor for other machining options.

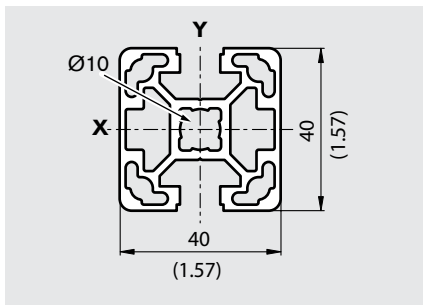

40x40 2S 



Features:

- Ideal for medium-duty construction
- Two closed T-slots provide neat, finished appearance
- Has two 10mm T-slots

Non-Machined End Finish Options	Part Number
Profile 40x40 2S, pkg. of 20, 6000mm long	3 842 529 363
Profile 40x40 2S, single, 6000mm long	3 842 529 364

Machined Options	End Finish	Part Number
Profile 40x40 2S, -/-, specify length $\geq 30\text{mm} \leq 6000\text{mm}$		3 842 993 187/ __mm
Profile 40x40 2S, M12/M12, specify length $\geq 110\text{mm} \leq 6000\text{mm}$		3 842 993 188/ __mm

Please contact your distributor for other machining options.

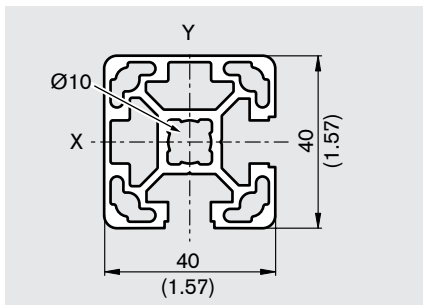

40x40 2SA 



Features:

- Ideal for medium-duty construction
- Two adjacent closed T-slots provide neat, finished appearance
- Has two adjacent 10mm T-slots

Non-Machined End Finish Options	Part Number
Profile 40x40 2SA, pkg. of 20, 6000mm long	3 842 529 365
Profile 40x40 2SA, single, 6000mm long	3 842 529 366

Machined Options	End Finish	Part Number
Profile 40x40 2SA, -/-, specify length $\geq 30\text{mm} \leq 6000\text{mm}$		3 842 993 189/ __mm
Profile 40x40 2SA, M12/M12, specify length $\geq 110\text{mm} \leq 6000\text{mm}$		3 842 993 190/ __mm

Please contact your distributor for other machining options.

Section 2: Profiles

40-Series Profiles

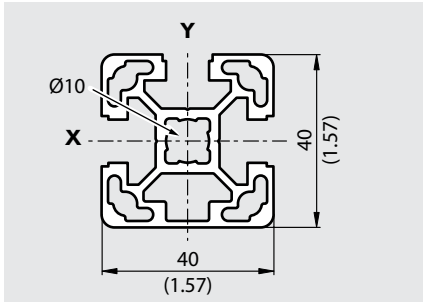

40x40 3S 



Features:

- Ideal for medium-duty construction
- Closed T-slot provides neat, finished appearance
- Has three 10mm T-slots

Non-Machined End Finish Options	Part Number
Profile 40x40 3S, pkg. of 20, 6000mm long	3 842 529 367
Profile 40x40 3S, single, 6000mm long	3 842 529 368

Machined Options	End Finish	Part Number
Profile 40x40 3S, -/-, specify length $\geq 30\text{mm} \leq 6000\text{mm}$		3 842 993 191/ __mm
Profile 40x40 3S, M12/M12, specify length $\geq 110\text{mm} \leq 6000\text{mm}$		3 842 993 192/ __mm

Please contact your distributor for other machining options.

40x40R 

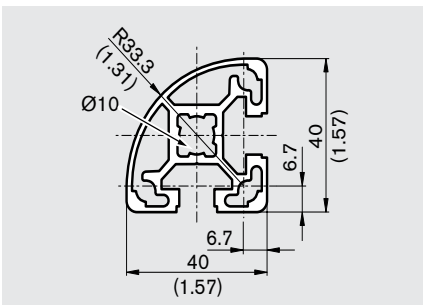

Features:

- Curved edge provides neat, finished appearance
- Has two 10mm T-slots

Non-Machined End Finish Options	Part Number
Profile 40x40R, pkg. of 20, 6000mm long	3 842 529 359
Profile 40x40R, single, 6000mm long	3 842 529 360

Machined Options	End Finish	Part Number
Profile 40x40R, -/-, specify length $\geq 30\text{mm} \leq 6000\text{mm}$		3 842 993 184/ __mm

Please contact your distributor for other machining options.

Section 2: Profiles

2

40x40HR 

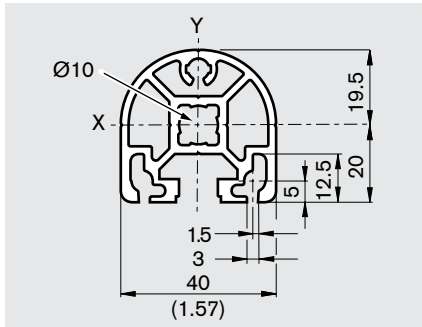

Features:

- Ideal for hand rails and other smoothed, finished edges
- Has one 10mm T-slot

Non-Machined End Finish Options

Part Number

Profile 40x40HR, pkg. of 20, 6000mm long

3 842 529 381

Profile 40x40HR, single, 6000mm long

3 842 529 382

Machined Options

End Finish

Part Number

Profile 40x40HR, -/-, specify length $\geq 30\text{mm} \leq 6000\text{mm}$



3 842 993 256/ __mm

Profile 40x40HR, M12/M12, specify length $\geq 110\text{mm} \leq 6000\text{mm}$



3 842 993 257/ __mm

Please contact your distributor for other machining options.

40x80 

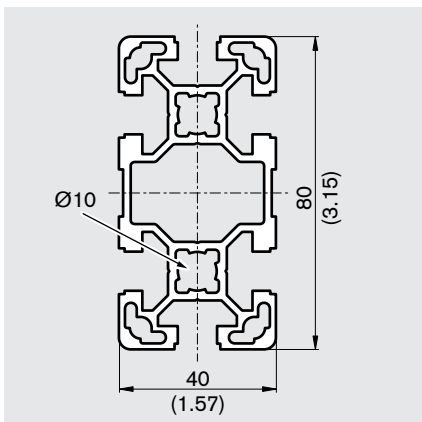

Features:

- Ideal for medium-duty, to heavy-duty construction, such as guarding, machine bases, etc.
- Has six 10mm T-slots

Non-Machined End Finish Options

Part Number

Profile 40x80, pkg. of 12, 6000mm long

3 842 529 341

Profile 40x80, single, 6000mm long

3 842 529 342

Machined Options

End Finish

Part Number

Profile 40x80, -/-, specify length $\geq 30\text{mm} \leq 6000\text{mm}$



3 842 993 130/ __mm

Profile 40x80, M12/-, specify length $\geq 55\text{mm} \leq 6000\text{mm}$



3 842 993 131/ __mm

Profile 40x80, D17VS/-, specify length $\geq 40\text{mm} \leq 6000\text{mm}$



3 842 993 137/ __mm

Profile 40x80, M12/M12, specify length $\geq 110\text{mm} \leq 6000\text{mm}$



3 842 993 132/ __mm

Profile 40x80, D17/D17, specify length $\geq 80\text{mm} \leq 6000\text{mm}$



3 842 993 135/ __mm

Profile 40x80, D17/D17VS, specify length $\geq 80\text{mm} \leq 6000\text{mm}$



3 842 993 136/ __mm

Profile 40x80, D17VS/D17VS, specify length $\geq 80\text{mm} \leq 6000\text{mm}$



3 842 993 138/ __mm

Please contact your distributor for other machining options.

Section 2: Profiles

40-Series Profiles

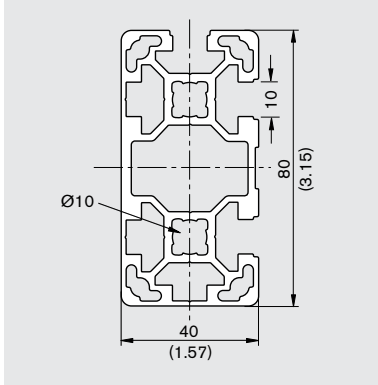
40x80 3SA **Features:**



- Ideal for medium-duty to heavy-duty applications such as machine frames and work benches.
- Has three 10mm T-slots
- Smooth on two sides

Non-Machined End Finish Options

Profile 40x80 3SA pkg. of 12, 6000mm long

Part Number**3 842 538 330**

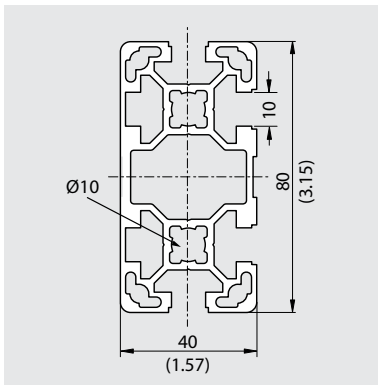
Profile 40x80 3SA, single, 6000mm long

3 842 538 329**Machined Options**Profile 40x80 3SA -/-, specify length $\geq 50\text{mm} \leq 6000\text{mm}$ **End Finish****Part Number****3 842 993 654/ __mm***Please contact your distributor for other machining options.*40x80 4S **Features:**

- Ideal for medium-duty to heavy-duty applications such as machine frames and work benches.
- Has four 10mm T-slots

Non-Machined End Finish Options

Profile 40x80 4S pkg. of 12, 6000mm long

Part Number**3 842 536 484**

Profile 40x80 4S, single, 6000mm long

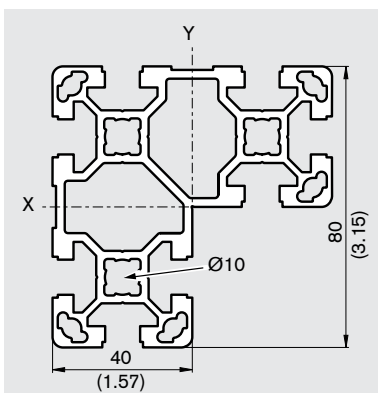
3 842 536 485**Machined Options**Profile 40x80 4S -/-, specify length $\geq 30\text{mm} \leq 6000\text{mm}$ **End Finish****Part Number****3 842 993 424/ __mm***Please contact your distributor for other machining options.*40x80x80 **Features:**

- Ideal for medium-duty to heavy-duty applications such as machine frames and work benches.
- Has eight 10mm T-slots

Non-Machined End Finish Options

Profile 40x80x80, pkg. of 8, 6000mm long

Part Number**3 842 537 827**

Profile 40x80x80, single, 6000mm long

3 842 529 370**Machined Options**Profile 40x80x80, -/-, specify length $\geq 30\text{mm} \leq 6000\text{mm}$ **End Finish****Part Number****3 842 993 193/ __mm***Please contact your distributor for other machining options.*

Section 2: Profiles

2



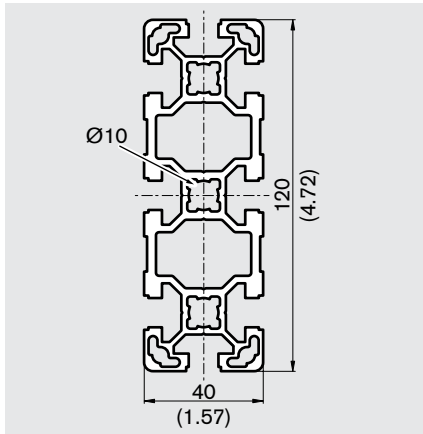

40x120 



Features:

- Ideal for heavy-duty applications where additional strength is needed, such as machine bases and work benches
- Suitable for linear motion applications
- Has eight 10mm T-slots

Non-Machined End Finish Options	Part Number
Profile 40x120, pkg. of 8, 6000mm long	3 842 537 824
Profile 40x120, single, 6000mm long	3 842 529 344

Machined Options	End Finish	Part Number
Profile 40x120, -/-, specify length $\geq 30\text{mm} \leq 6000\text{mm}$		3 842 993 139/ __mm
Profile 40x120, M12/-, specify length $\geq 55\text{mm} \leq 6000\text{mm}$		3 842 993 140/ __mm
Profile 40x120, M12/M12, specify length $\geq 110\text{mm} \leq 6000\text{mm}$		3 842 993 141/ __mm
Profile 40x120, D17/D17, specify length $\geq 80\text{mm} \leq 6000\text{mm}$		3 842 993 142/ __mm
Profile 40x120, D17VS/D17VS, specify length $\geq 80\text{mm} \leq 6000\text{mm}$		3 842 993 225/ __mm

Please contact your distributor for other machining options.



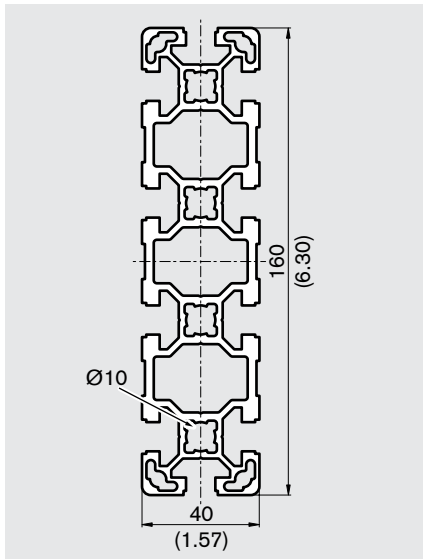

40x160 



Features:

- Ideal for heavy-duty applications where additional strength is needed, such as machine bases and work benches
- Suitable for linear motion applications
- Has ten 10mm T-slots

Non-Machined End Finish Options	Part Number
Profile 40x160, pkg. of 6, 6000mm long	3 842 529 345
Profile 40x160, single, 6000mm long	3 842 529 346

Machined Options	End Finish	Part Number
Profile 40x160, -/-, specify length $\geq 30\text{mm} \leq 6000\text{mm}$		3 842 993 143/ __mm
Profile 40x160, M12/-, specify length $\geq 55\text{mm} \leq 6000\text{mm}$		3 842 993 144/ __mm
Profile 40x160, M12/M12, specify length $\geq 110\text{mm} \leq 6000\text{mm}$		3 842 993 145/ __mm
Profile 40x160, D17/D17, specify length $\geq 80\text{mm} \leq 6000\text{mm}$		3 842 993 146/ __mm

Please contact your distributor for other machining options.

Section 2: Profiles

45-Series Profiles

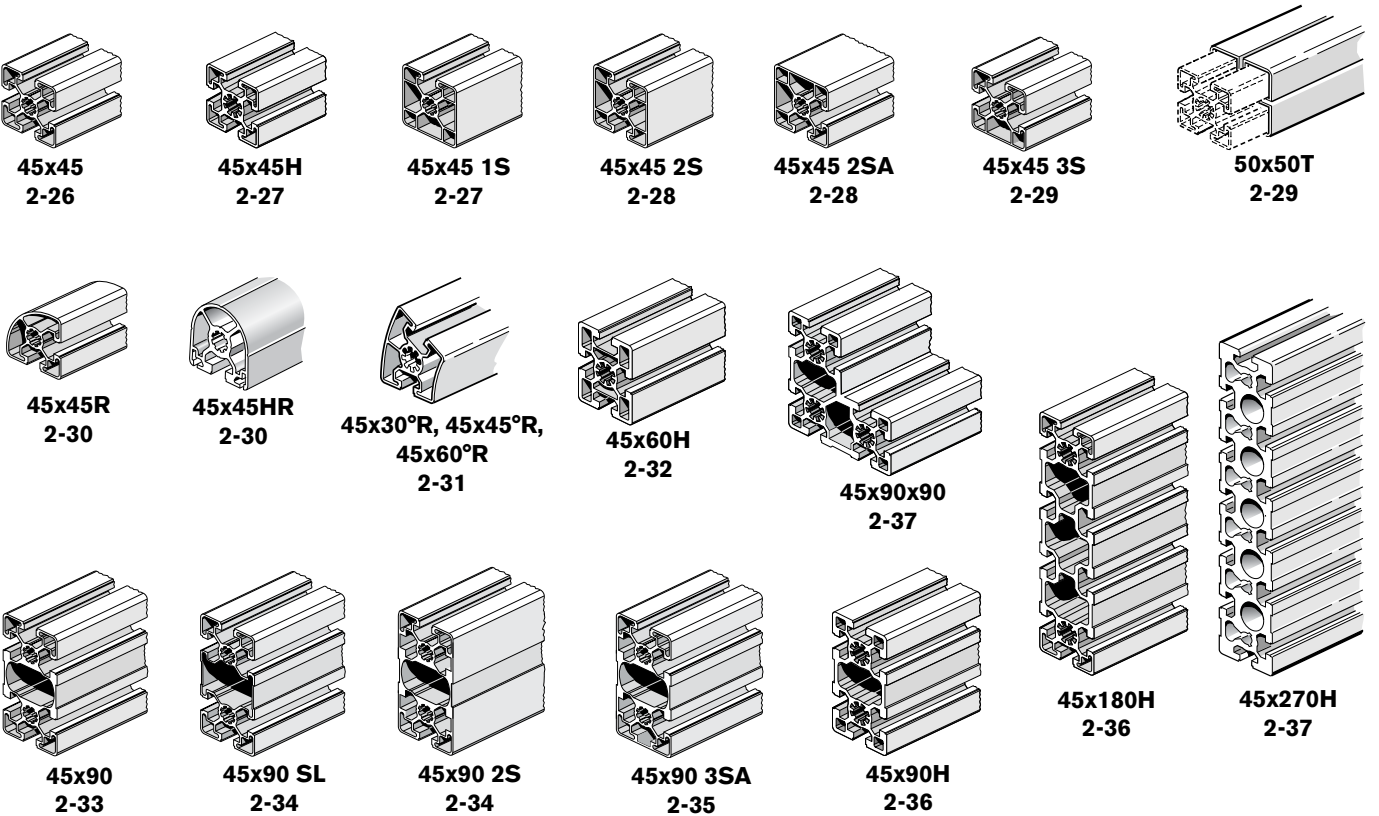

45x45 ¹⁰ GoTo

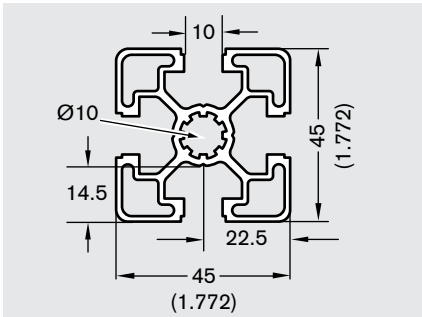

Features:

- General purpose, medium-duty profile for a wide variety of applications
- Has four 10mm T-slots

Non-Machined End Finish Options

	Part Number
Profile 45x45, pkg. of 20, 6000mm long	8 981 004 744 GoTo
Profile 45x45, single, 6000mm long	8 981 004 773 GoTo

Machined Options

	End Finish	Part Number
Profile 45x45, -/-, specify length $\geq 30\text{mm} \leq 6000\text{mm}$		8 981 992 026/ __mm
Profile 45x45, M12/-, specify length $\geq 55\text{mm} \leq 6000\text{mm}$		8 981 992 027/ __mm
Profile 45x45, M12-D9.8-D9.8VS/-, specify length $\geq 55\text{mm} \leq 6000\text{mm}$		8 981 992 030/ __mm
Profile 45x45, M12/M12, specify length $\geq 110\text{mm} \leq 6000\text{mm}$		8 981 992 028/ __mm
Profile 45x45, M12-D9.8-D9.8VS/M12-D9.8-D9.8VS, specify length $\geq 110\text{mm} \leq 6000\text{mm}$		8 981 992 032/ __mm
Profile 45x45, D9.8/D9.8, specify length $\geq 80\text{mm} \leq 6000\text{mm}$		3 842 992 967/ __mm

Please contact your distributor for other machining options.

GoTo boschrexroth-us.com/framing to get these in stock items **FAST** from your local distributor

Section 2: Profiles

2



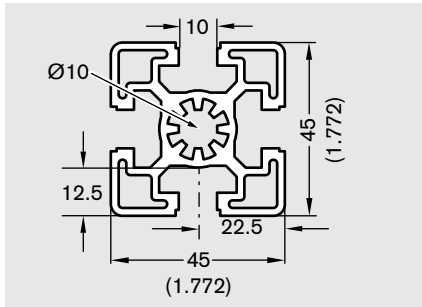









45x45H  **Goto**



Features:

- General purpose, thicker-walled profile for strong, rugged performance
- Has four 10mm T-slots

Non-Machined End Finish Options	Part Number
Profile 45x45H, pkg. of 20, 6000mm long	3 842 315 100 Goto
Profile 45x45H, single, 6000mm long	3 842 507 125 Goto

Machined Options	End Finish	Part Number
Profile 45x45H, -/-, specify length $\geq 30\text{mm} \leq 6000\text{mm}$		3 842 990 520/ __mm
Profile 45x45H, M12/-, specify length $\geq 55\text{mm} \leq 6000\text{mm}$		3 842 990 517/ __mm
Profile 45x45H, M16/-, specify length $\geq 115\text{mm} \leq 6000\text{mm}$		3 842 990 521/ __mm
Profile 45x45H, D17/-, specify length $\geq 40\text{mm} \leq 6000\text{mm}$		3 842 990 648/ __mm
Profile 45x45H, M12/M12, specify length $\geq 110\text{mm} \leq 6000\text{mm}$		3 842 990 518/ __mm
Profile 45x45H, M16/M12, specify length $\geq 175\text{mm} \leq 6000\text{mm}$		3 842 990 519/ __mm
Profile 45x45H, M16/M16, specify length $\geq 240\text{mm} \leq 6000\text{mm}$		3 842 990 522/ __mm
Profile 45x45H, M12/D17 specify length $\geq 90\text{mm} \leq 6000\text{mm}$		3 842 990 640/ __mm
Profile 45x45H, M16/D17, specify length $\geq 165\text{mm} \leq 6000\text{mm}$		3 842 990 642/ __mm
Profile 45x45H, M12-D9.8-D9.8VS/M12-D9.8-D9.8VS, specify length $\geq 110\text{mm} \leq 6000\text{mm}$		3 842 992 372/ __mm
Profile 45x45H, D9.8/D9.8, specify length $\geq 80\text{mm} \leq 6000\text{mm}$		3 842 992 969/ __mm
Profile 45x45H, D17/D17, specify length $\geq 80\text{mm} \leq 6000\text{mm}$		3 842 990 644/ __mm
Profile 45x45H, D17/D17VS, specify length $\geq 80\text{mm} \leq 6000\text{mm}$		3 842 990 646/ __mm

Please contact your distributor for other machining options.

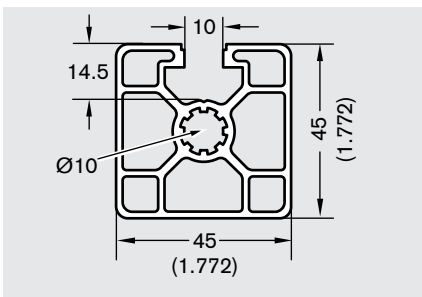

45x45 1S 



Features:

- Closed T-slots provide neat, finished appearance
- Has one 10mm T-slot

Non-Machined End Finish Options	Part Number
Profile 45x45 1S, pkg. of 20, 5600mm long	3 842 506 956
Profile 45x45 1S, single, 5600mm long	3 842 506 960

Machined Options	End Finish	Part Number
Profile 45x45 1S, -/-, specify length $\geq 30\text{mm} \leq 5600\text{mm}$		3 842 992 401/ __mm
Profile 45x45 1S, M12/M12, specify length $\geq 110\text{mm} \leq 5600\text{mm}$		3 842 992 405/ __mm

Please contact your distributor for other machining options.

Section 2: Profiles

45-Series Profiles

45x45 2S

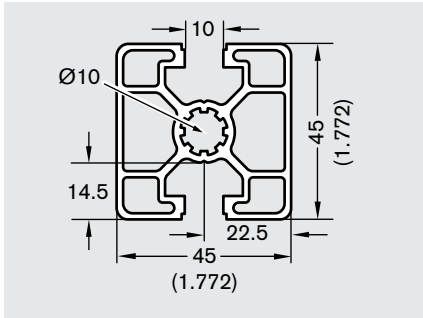



Features:

- Closed T-slots provide neat, finished appearance
- Has two 10mm T-slots

Non-Machined End Finish Options

	Part Number
Profile 45x45 2S, pkg. of 20, 5600mm long	3 842 506 958
Profile 45x45 2S, single, 5600mm long	3 842 506 962

Machined Options

	End Finish	Part Number
Profile 45x45 2S, -/-, specify length $\geq 30\text{mm} \leq 5600\text{mm}$		3 842 992 403/ __mm
Profile 45x45 2S, M12/M12, specify length $\geq 110\text{mm} \leq 5600\text{mm}$		3 842 992 407/ __mm

Please contact your distributor for other machining options.

45x45 2SA

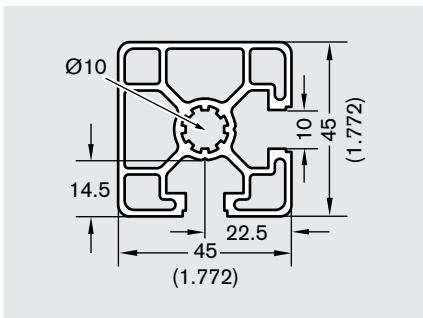



Features:

- Closed T-slots provide neat, finished appearance
- Has two adjacent 10mm T-slots

Non-Machined End Finish Options

	Part Number
Profile 45x45 2SA, pkg. of 20, 5600mm long	3 842 506 957
Profile 45x45 2SA, single, 5600mm long	3 842 506 961

Machined Options

	End Finish	Part Number
Profile 45x45 2SA, -/-, specify length $\geq 30\text{mm} \leq 5600\text{mm}$		3 842 992 402/ __mm
Profile 45x45 2SA, M12/M12, specify length $\geq 110\text{mm} \leq 5600\text{mm}$		3 842 992 406/ __mm

Please contact your distributor for other machining options.

Section 2: Profiles

2

45x45 3S 

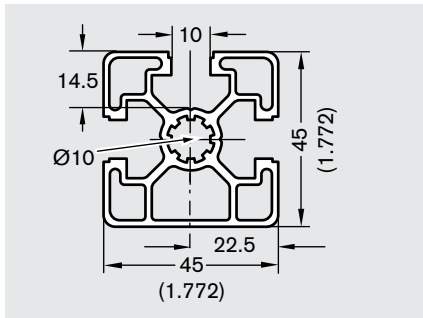

Features:

- Closed T-slot provides neat, finished appearance
- Has three 10mm T-slots

Non-Machined End Finish Options

Profile 45x45 3S, pkg. of 20, 5600mm long	3 842 506 959
Profile 45x45 3S, single, 5600mm long	3 842 506 963

Part Number

Machined Options

Profile 45x45 3S, -/-, specify length $\geq 30\text{mm} \leq 5600\text{mm}$

End Finish



Part Number

3 842 992 404/ __mm

Profile 45x45 3S, M12/M12, specify length $\geq 110\text{mm} \leq 5600\text{mm}$



3 842 992 408/ __mm

Please contact your distributor for other machining options.

50x50T 

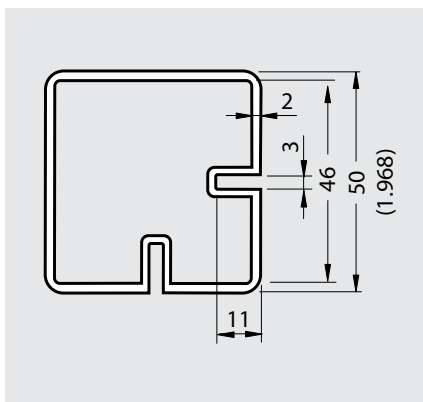

Features:

- Fits over 45x45H, 45x45, 45x45 3S, and 45x45 2SA profiles to create a telescoping sleeve
- Locks in place with a T-block and screw (sold separately, listed below)
- Two 3mm slots accept 3mm thick panels
- Use to create sliding doors, telescoping legs, and other adjustable structures

Non-Machined End Finish Options

Profile 50x50T, pkg. of 6, 5600mm long	3 842 537 817
Profile 50x50T, single, 5600mm long	3 842 537 847
T-Block, M8, one	3 842 528 735
Button-head screw, DIN 9427 M8x12	3 842 516 565

Part Number

Machined Options

Profile 50x50T, -/-, specify length $\geq 30\text{mm} \leq 5600\text{mm}$

End Finish



Part Number

3 842 992 913/ __mm

Please contact your distributor for other machining options.

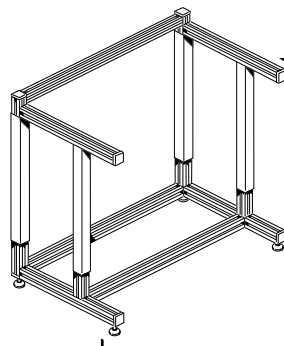

Helpful Hint

button-head screw
10mm T-block

Create a locking telescope section with 10mm T-blocks by drilling an 8.2mm dia. access hole in the side of the 50 x 50T profile.

Section 2: Profiles

45-Series Profiles

45x45R 

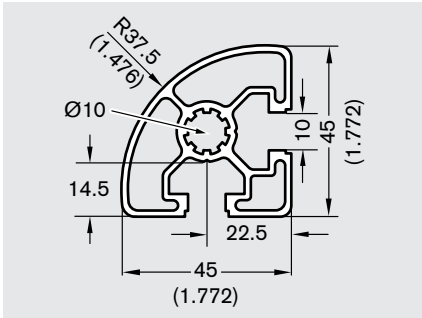

Features:

- Curved edge provides neat, finished appearance
- Has two 10mm T-slots

Non-Machined End Finish Options

	Part Number
Profile 45x45R, pkg. of 20, 5600mm long	3 842 517 200
Profile 45x45R, single, 5600mm long	3 842 517 199

Machined Options

	End Finish	Part Number
Profile 45x45R, -/-, specify length $\geq 30\text{mm} \leq 5600\text{mm}$		3 842 992 897/ __mm

Please contact your distributor for other machining options.

45x45HR 

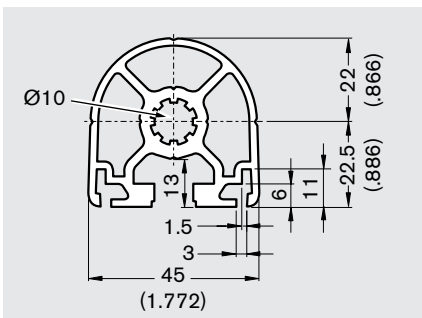



Features:

- Ideal for hand rails and other smoothed, finished edges
- Has one 10mm T-slot

Non-Machined End Finish Options

	Part Number
Profile 45x45HR, pkg. of 20, 5600mm long	3 842 525 505
Profile 45x45HR, single, 5600mm long	3 842 525 504

Machined Options

	End Finish	Part Number
Profile 45x45HR, -/-, specify length $\geq 30\text{mm} \leq 5600\text{mm}$		3 842 992 945/ __mm
Profile 45x45HR, M12/M12, specify length $\geq 110\text{mm} \leq 5600\text{mm}$		3 842 992 999/ __mm
Profile 45x45HR, -/M12, specify length $\geq 55\text{mm} \leq 5600\text{mm}$		3 842 993 001/ __mm

Please contact your distributor for other machining options.

Section 2: Profiles

2

45x30°R 

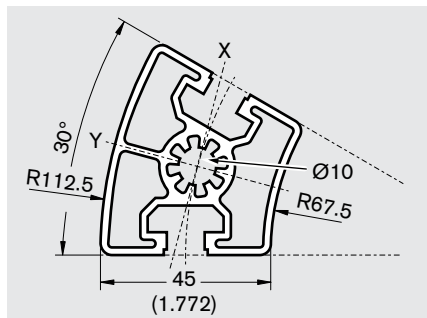

Features:

- Provides high-tech appearance
- Curved surfaces ideal for following machine or space contours
- Has two 10mm T-slots

Non-Machined End Finish Options

- Profile 45x30°R, pkg. of 20, 5600mm long
- Profile 45x30°R, single, 5600mm long

Part Number

- 3 842 524 040**
- 3 842 524 039**

Machined Options

Profile 45x30°R, -/-, specify length $\geq 30\text{mm} \leq 5600\text{mm}$

End Finish



Part Number

3 842 993 013/ __mm

Please contact your distributor for other machining options.

45x45°R 

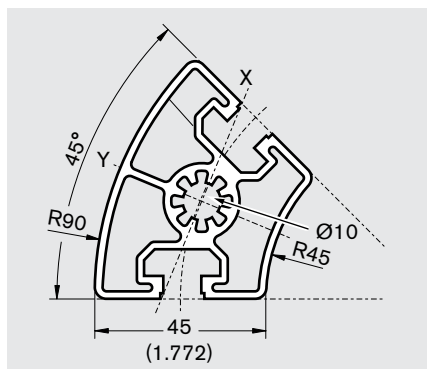

Features:

- Provides high-tech appearance
- Curved surfaces ideal for following machine or space contours
- Has two 10mm T-slots

Non-Machined End Finish Options

- Profile 45x45°R, pkg. of 20, 5600mm long
- Profile 45x45°R, single, 5600mm long

Part Number

- 3 842 524 043**
- 3 842 524 042**

Machined Options

Profile 45x45°R, -/-, specify length $\geq 30\text{mm} \leq 5600\text{mm}$

End Finish



Part Number

3 842 993 014/ __mm

Please contact your distributor for other machining options.

45x60°R 

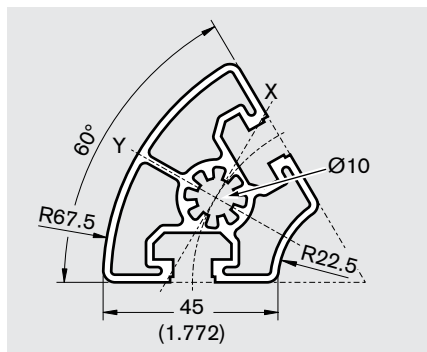

Features:

- Provides high-tech appearance
- Curved surfaces ideal for following machine or space contours
- Has two 10mm T-slots

Non-Machined End Finish Options

- Profile 45x60°R, pkg. of 20, 5600mm long
- Profile 45x60°R, single, 5600mm long

Part Number

- 3 842 524 046**
- 3 842 524 045**

Machined Options

Profile 45x60°R, -/-, specify length $\geq 30\text{mm} \leq 5600\text{mm}$

End Finish



Part Number

3 842 993 015/ __mm

Please contact your distributor for other machining options.

Section 2: Profiles

45-Series Profiles

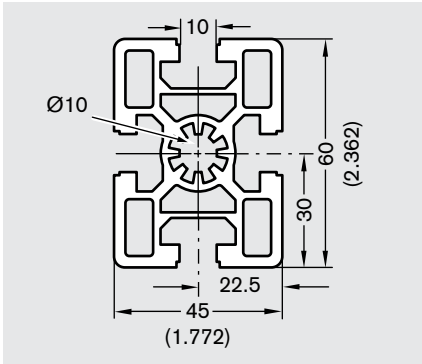

45x60H

























Features:

- General purpose, medium-duty profile for strong, rugged performance
- Has four 10mm T-slots

Non-Machined End Finish Options

	Part Number
Profile 45x60H, pkg. of 20, 6000mm long	3 842 315 122 
Profile 45x60H, single, 6000mm long	3 842 507 127 

Machined Options

	End Finish	Part Number
Profile 45x60H, -/-, specify length $\geq 50\text{mm} \leq 6000\text{mm}$		3 842 990 570/ __mm
Profile 45x60H, M12/-, specify length $\geq 55\text{mm} \leq 6000\text{mm}$		3 842 990 571/ __mm
Profile 45x60H, M16/-, specify length $\geq 120\text{mm} \leq 6000\text{mm}$		3 842 990 573/ __mm
Profile 45x60H, F1/-, specify length $\geq 55\text{mm} \leq 6000\text{mm}$		3 842 990 586/ __mm
Profile 45x60H, F2/-, specify length $\geq 55\text{mm} \leq 6000\text{mm}$		3 842 990 625/ __mm
Profile 45x60H, D9.8/-, specify length $\geq 40\text{mm} \leq 6000\text{mm}$		3 842 992 376/ __mm
Profile 45x60H, D9.8VS/-, specify length $\geq 40\text{mm} \leq 6000\text{mm}$		3 842 992 375/ __mm
Profile 45x60H, D17/-, specify length $\geq 40\text{mm} \leq 6000\text{mm}$		3 842 990 688/ __mm
Profile 45x60H, D17VS/-, specify length $\geq 40\text{mm} \leq 6000\text{mm}$		3 842 990 690/ __mm
Profile 45x60H, M12/M12, specify length $\geq 110\text{mm} \leq 6000\text{mm}$		3 842 990 572/ __mm
Profile 45x60H, M16/M12, specify length $\geq 175\text{mm} \leq 6000\text{mm}$		3 842 990 575/ __mm
Profile 45x60H, M12/F1, specify length $\geq 110\text{mm} \leq 6000\text{mm}$		3 842 990 592/ __mm
Profile 45x60H, M16/D17, specify length $\geq 165\text{mm} \leq 6000\text{mm}$		3 842 990 668/ __mm
Profile 45x60H, M16/D17VS, specify length $\geq 165\text{mm} \leq 6000\text{mm}$		3 842 990 666/ __mm
Profile 45x60H, M16/F1, specify length $\geq 165\text{mm} \leq 6000\text{mm}$		3 842 990 594/ __mm
Profile 45x60H, D17/D17, specify length $\geq 80\text{mm} \leq 6000\text{mm}$		3 842 990 672/ __mm
Profile 45x60H, D17/D17VS, specify length $\geq 80\text{mm} \leq 6000\text{mm}$		3 842 990 674/ __mm
Profile 45x60H, D17VS/D17VS, specify length $\geq 80\text{mm} \leq 6000\text{mm}$		3 842 990 670/ __mm
Profile 45x60H, F1/F1, specify length $\geq 110\text{mm} \leq 6000\text{mm}$		3 842 990 584/ __mm
Profile 45x60H, F1/F1VS, specify length $\geq 55\text{mm} \leq 6000\text{mm}$		3 842 990 630/ __mm
Profile 45x60H, F2/F2, specify length $\geq 100\text{mm} \leq 6000\text{mm}$		3 842 992 491/ __mm
Profile 45x60H, D17LF/D17LF, specify length $\geq 80\text{mm} \leq 6000\text{mm}$		3 842 993 085/ __mm

Please contact your distributor for other machining options.

Section 2: Profiles

2

45x90 

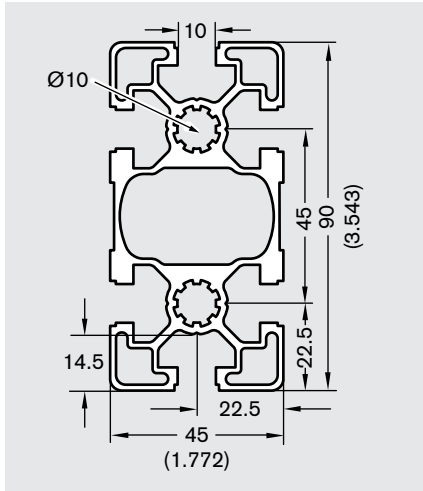

Features:

- Heavy-duty profile for strong, rugged performance
- Has six 10mm T-slots

Non-Machined End Finish Options











Part Number

Profile 45x90, pkg. of 12, 5600mm long	3 842 511 782 <i>GoTo</i>
Profile 45x90, single, 5600mm long	3 842 511 781 <i>GoTo</i>

Machined Options

End Finish

Part Number

Profile 45x90, -/-, specify length $\geq 50\text{mm} \leq 5600\text{mm}$		3 842 992 432/ _mm
Profile 45x90, M12/-, specify length $\geq 55\text{mm} \leq 5600\text{mm}$		3 842 992 453/ _mm
Profile 45x90, D17/-, specify length $\geq 40\text{mm} \leq 5600\text{mm}$		3 842 992 451/ _mm
Profile 45x90, D17VS/-, specify length $\geq 40\text{mm} \leq 5600\text{mm}$		3 842 992 452/ _mm
Profile 45x90, M12/M12, specify length $\geq 110\text{mm} \leq 5600\text{mm}$		3 842 992 433/ _mm
Profile 45x90, M12/D17, specify length $\geq 90\text{mm} \leq 5600\text{mm}$		3 842 992 434/ _mm
Profile 45x90, D17/D17, specify length $\geq 80\text{mm} \leq 5600\text{mm}$		3 842 992 437/ _mm
Profile 45x90, D17VS/D17, specify length $\geq 80\text{mm} \leq 5600\text{mm}$		3 842 992 436/ _mm
Profile 45x90, D17VS/D17VS, specify length $\geq 80\text{mm} \leq 5600\text{mm}$		3 842 992 435/ _mm
Profile 45x90, D17LF/D17LF, specify length $\geq 80\text{mm} \leq 5600\text{mm}$		3 842 993 084/ _mm

Please contact your distributor for other machining options.

Section 2: Profiles

45x90 SL 

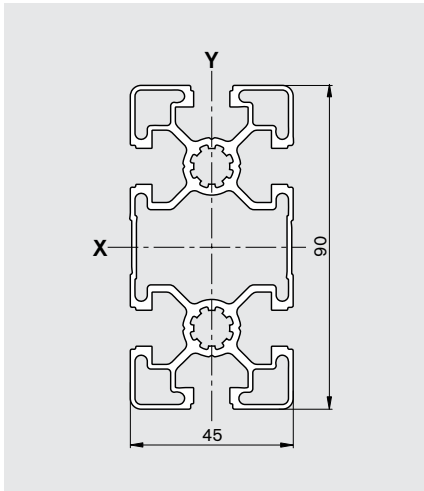

Features:

- Lighter duty applications
- Has six 10mm T-slots

Non-Machined End Finish Options	Part Number
Profile 45x90 SL, pkg. of 12, 6000mm long	3 842 537 102
Profile 45x90 SL, single, 6000mm long	3 842 537 103

Machined Options	End Finish	Part Number
Profile 45x90 SL, -/-, specify length $\geq 50\text{mm} \leq 6000\text{mm}$		3 842 993 450/ __mm

Please contact your distributor for other machining options.



45x90 2S 

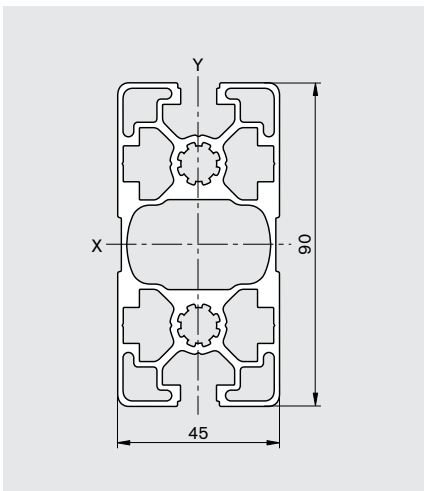

Features:

- Closed profile sides for cleanliness and aesthetics
- Has two 10mm T-slots

Non-Machined End Finish Options	Part Number
Profile 45x90 2S, pkg. of 12, 6000mm long	3 842 538 299
Profile 45x90 2S, single, 6000mm long	3 842 538 303

Machined Options	End Finish	Part Number
Profile 45x90 2S, -/-, specify length $\geq 50\text{mm} \leq 6000\text{mm}$		3 842 993 644/ __mm

Please contact your distributor for other machining options.



Section 2: Profiles

2

NEW!

45x90 3SA 

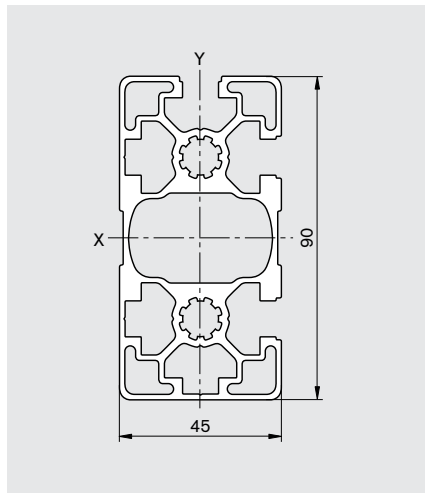

Features:

- Closed profile side for cleanliness and aesthetics
- Has three 10mm T-slots

Non-Machined End Finish Options	Part Number
Profile 45x90 3SA, pkg. of 12, 6000mm long	3 842 538 298
Profile 45x90 3SA, single, 6000mm long	3 842 538 302

Machined Options	End Finish	Part Number
Profile 45x90 3SA, -/-, specify length $\geq 55\text{mm} \leq 6000\text{mm}$	<input type="text"/>	3 842 993 635/ __mm

Please contact your distributor for other machining options.

Section 2: Profiles

45-Series Profiles

45x90H ¹⁰

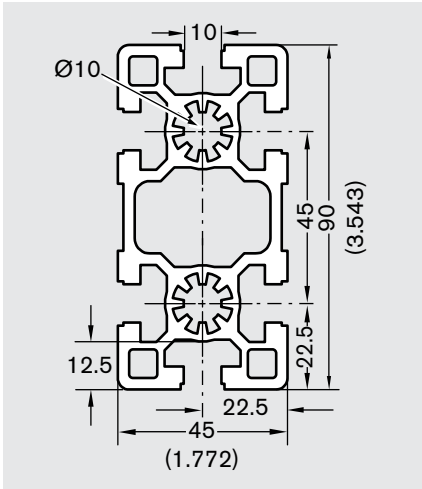

Features:

- Heavy-duty profile for strong, rugged performance
- Center channel can be used as an air manifold
- Has six 10mm T-slots

Non-Machined End Finish Options

	Part Number
Profile 45x90H, pkg. of 12, 6000mm long	3 842 315 123
Profile 45x90H, single, 6000mm long	3 842 507 123

Machined Options

Machined Options	End Finish	Part Number
Profile 45x90H, -/-, specify length $\geq 50\text{mm} \leq 6000\text{mm}$		3 842 990 300/ __mm
Profile 45x90H, M12/-, specify length $\geq 55\text{mm} \leq 6000\text{mm}$		3 842 990 301/ __mm
Profile 45x90H, M16/-, specify length $\geq 120\text{mm} \leq 6000\text{mm}$		3 842 990 303/ __mm
Profile 45x90H, M16/M16, specify length $\geq 240\text{mm} \leq 6000\text{mm}$		3 842 990 304/ __mm
Profile 45x90H, -/D17, specify length $\geq 40\text{mm} \leq 6000\text{mm}$		3 842 990 329/ __mm
Profile 45x90H, -/D17VS, specify length $\geq 40\text{mm} \leq 6000\text{mm}$		3 842 990 331/ __mm
Profile 45x90H, M12/M12, specify length $\geq 110\text{mm} \leq 6000\text{mm}$		3 842 990 302/ __mm
Profile 45x90H, M12/D17, specify length $\geq 90\text{mm} \leq 6000\text{mm}$		3 842 990 323/ __mm
Profile 45x90H, M12/D17VS, specify length $\geq 90\text{mm} \leq 6000\text{mm}$		3 842 990 305/ __mm
Profile 45x90H, M16/D17, specify length $\geq 165\text{mm} \leq 6000\text{mm}$		3 842 990 325/ __mm
Profile 45x90H, M16/D17VS, specify length $\geq 165\text{mm} \leq 6000\text{mm}$		3 842 990 307/ __mm
Profile 45x90H, D17/D17, specify length $\geq 80\text{mm} \leq 6000\text{mm}$		3 842 990 313/ __mm
Profile 45x90H, D17VS/D17, specify length $\geq 80\text{mm} \leq 6000\text{mm}$		3 842 990 311/ __mm
Profile 45x90H, D17VS/D17VS, specify length $\geq 80\text{mm} \leq 6000\text{mm}$		3 842 990 309/ __mm

Please contact your distributor for other machining options.

Section 2: Profiles

2

45x90x90 

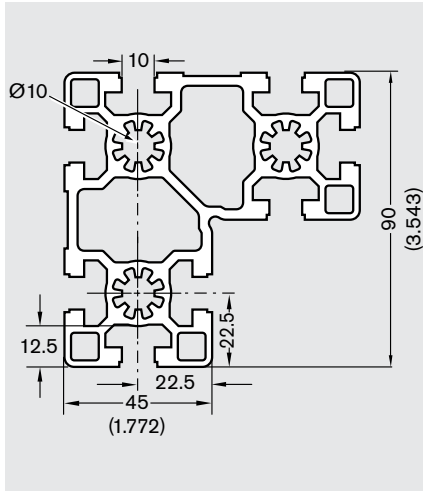

Features:

- Heavy-duty profile applications where extra strength is needed, such as machine bases and frames, support columns, etc.
- Has eight 10mm T-slots

Non-Machined End Finish Options

- Profile 45x90x90, pkg. of 8, 6000mm long
- Profile 45x90x90, single, 6000mm long

Part Number

- 3 842 537 823**
- 3 842 537 846**

Machined Options

- Profile 45x90x90, -/-, specify length $\geq 40\text{mm} \leq 6000\text{mm}$
- Profile 45x90x90, M12/-, specify length $\geq 40\text{mm} \leq 6000\text{mm}$

End Finish



Part Number

- 3 842 992 387/ __mm**
- 3 842 992 388/ __mm**

Please contact your distributor for other machining options.

Design Engineering Tip

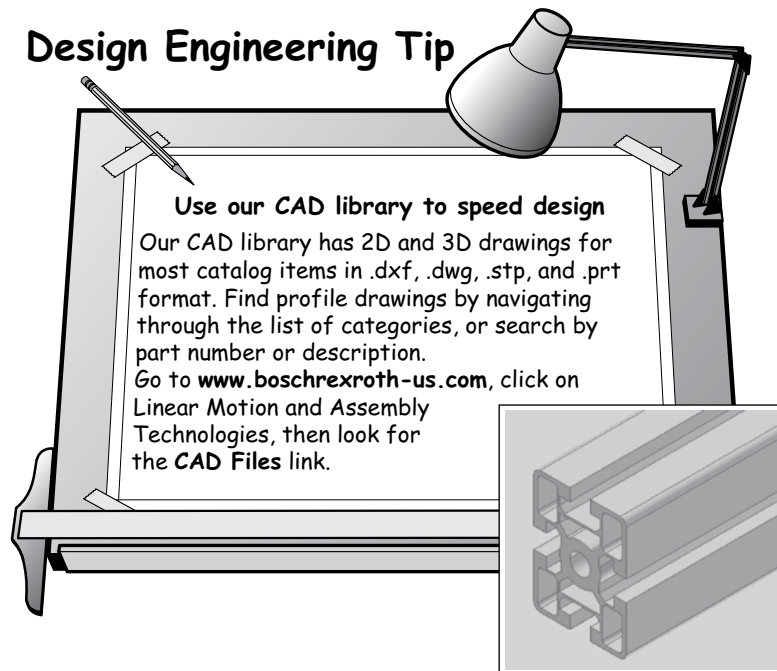

Use our CAD library to speed design

Our CAD library has 2D and 3D drawings for most catalog items in .dxf, .dwg, .stp, and .prt format. Find profile drawings by navigating through the list of categories, or search by part number or description. Go to www.boschrexroth-us.com, click on Linear Motion and Assembly Technologies, then look for the CAD Files link.

Section 2: Profiles

45-Series Profiles

45x180H

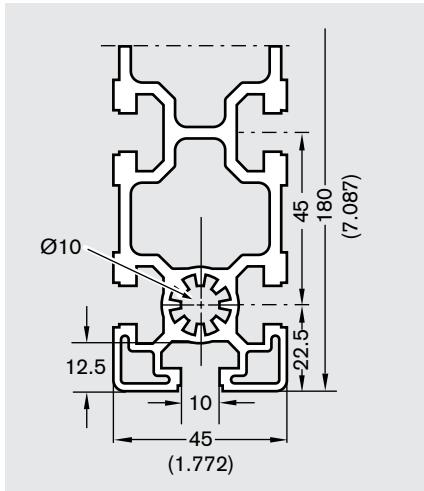

Features:

- Heavy-duty profile applications where extra strength is needed, such as machine bases and frames, support columns, etc.
- Center channels allow use as a three-port air bar
- Has ten 10mm T-slots











End view of complete profile



Non-Machined End Finish Options

	Part Number
Profile 45x180H, pkg. of 6, 5600mm long	3 842 509 187
Profile 45x180H, single, 5600mm long	3 842 509 201

Machined Options

	End Finish	Part Number
Profile 45x180H, -/-, specify length $\geq 50\text{mm} \leq 5600\text{mm}$		3 842 990 335/ __mm
Profile 45x180H, M12/-, specify length $\geq 55\text{mm} \leq 5600\text{mm}$		3 842 990 336/ __mm
Profile 45x180H, D17/-, specify length $\geq 40\text{mm} \leq 5600\text{mm}$		3 842 990 337/ __mm
Profile 45x180H, D17VS/-, specify length $\geq 40\text{mm} \leq 5600\text{mm}$		3 842 990 338/ __mm
Profile 45x180H, M12/M12, specify length $\geq 110\text{mm} \leq 5600\text{mm}$		3 842 990 339/ __mm
Profile 45x180H, M12/D17, specify length $\geq 90\text{mm} \leq 5600\text{mm}$		3 842 990 340/ __mm
Profile 45x180H, M12/D17VS, specify length $\geq 90\text{mm} \leq 5600\text{mm}$		3 842 990 341/ __mm
Profile 45x180H, D17/D17, specify length $\geq 80\text{mm} \leq 5600\text{mm}$		3 842 990 342/ __mm
Profile 45x180H, D17/D17VS, specify length $\geq 80\text{mm} \leq 5600\text{mm}$		3 842 990 343/ __mm
Profile 45x180H, D17VS/D17VS, specify length $\geq 80\text{mm} \leq 5600\text{mm}$		3 842 990 344/ __mm

Please contact your distributor for other machining options.

Section 2: Profiles

45x270H 

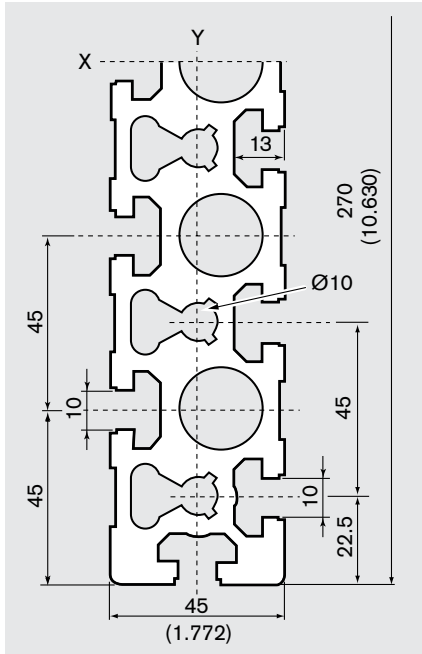

Features:

- Heavy-duty profile applications where extra strength is needed, such as machine bases and frames, support columns, etc.
- Has thirteen 10mm T-slots

End view of complete profile





Non-Machined End Finish Options

- Profile 45x270H, pkg. of 2, 5600mm long
- Profile 45x270H, single, 5600mm long

Part Number

- 3 842 520 025**
- 3 842 520 024**

Machined Options

Machined Options	End Finish	Part Number
Profile 45x270H, -/-, specify length $\geq 50\text{mm} \leq 5600\text{mm}$		3 842 992 927/ __mm
Profile 45x270H, M12/M12 (all holes), specify length $\geq 110\text{mm} \leq 5600\text{mm}$		3 842 992 455/ __mm
Profile 45x270H, M12/M12 (linear guide), specify length $\geq 110\text{mm} \leq 5600\text{mm}$		3 842 992 928/ __mm
Profile 45x270H, D17VS/D17VS, specify length $\geq 80\text{mm} \leq 5600\text{mm}$		3 842 992 930/ __mm

Please contact your distributor for other machining options.

Application Hint

To order 45x270H with the holes tapped for use as a carriage on the LF20S dynamic linear element system, order 3 842 992 928/ __.

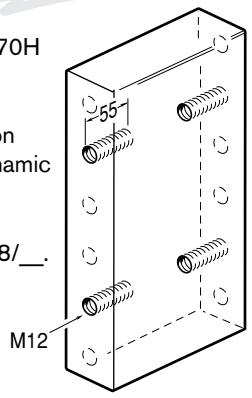

Section 2: Profiles

50-Series Profiles

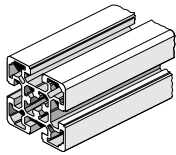

50x50
2-40

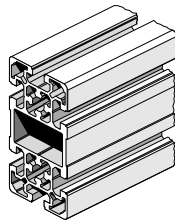

50x100
2-41

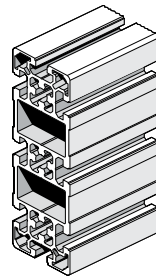

50x150
2-42

50x50

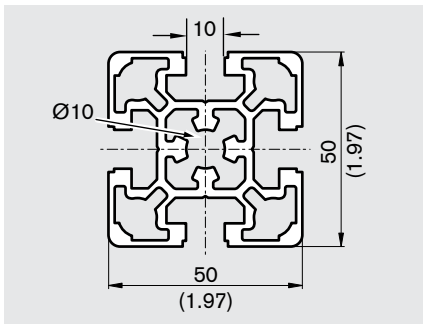

Features:

- General purpose, heavy-duty profile for strong, rugged performance
- Has four 10mm T-slots

Non-Machined End Finish Options

- Profile 50x50, pkg. of 20, 6000mm long
- Profile 50x50, single, 6000mm long

Part Number

- 3 842 529 351**
- 3 842 529 352**

Machined Options

Machined Options	End Finish	Part Number
Profile 50x50 -/-, specify length $\geq 30\text{mm} \leq 6000\text{mm}$		3 842 993 156/ __mm
Profile 50x50 M12/-, specify length $\geq 55\text{mm} \leq 6000\text{mm}$		3 842 993 157/ __mm
Profile 50x50 D17/-, specify length $\geq 40\text{mm} \leq 6000\text{mm}$		3 842 993 160/ __mm
Profile 50x50 M12/M12, specify length $\geq 110\text{mm} \leq 6000\text{mm}$		3 842 993 158/ __mm
Profile 50x50 M12/D17, specify length $\geq 90\text{mm} \leq 6000\text{mm}$		3 842 993 159/ __mm
Profile 50x50 D17/D17, specify length $\geq 80\text{mm} \leq 6000\text{mm}$		3 842 993 161/ __mm
Profile 50x50 D17/D17VS, specify length $\geq 80\text{mm} \leq 6000\text{mm}$		3 842 993 162/ __mm
Profile 50x50 D9.8/D9.8, specify length $\geq 80\text{mm} \leq 6000\text{mm}$		3 842 993 164/ __mm

Please contact your distributor for other machining options.

Section 2: Profiles

2

50x100 

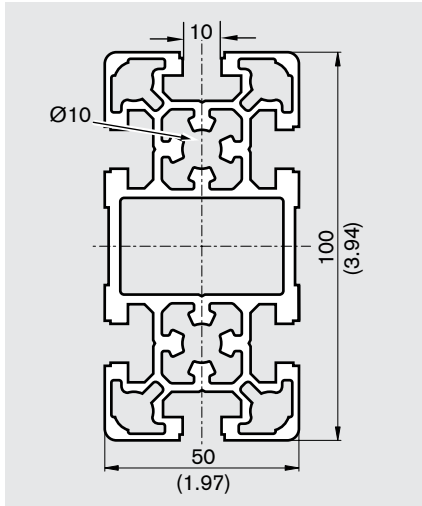

Features:

- Heavy-duty profile where high strength is a must
- Has six 10mm T-slots

Non-Machined End Finish Options







Part Number

Profile 50x100, pkg. of 10, 6000mm long	3 842 537 825
Profile 50x100, single, 6000mm long	3 842 529 354

Machined Options

End Finish

Part Number

Profile 50x100 -/-, specify length $\geq 30\text{mm} \leq 6000\text{mm}$		3 842 993 163/ __mm
Profile 50x100 M12/-, specify length $\geq 55\text{mm} \leq 6000\text{mm}$		3 842 993 165/ __mm
Profile 50x100 D17VS/-, specify length $\geq 40\text{mm} \leq 6000\text{mm}$		3 842 993 169/ __mm
Profile 50x100 M12/M12, specify length $\geq 110\text{mm} \leq 6000\text{mm}$		3 842 993 166/ __mm
Profile 50x100 D17/D17, specify length $\geq 80\text{mm} \leq 6000\text{mm}$		3 842 993 167/ __mm
Profile 50x100 D17/D17VS, specify length $\geq 80\text{mm} \leq 6000\text{mm}$		3 842 993 168/ __mm
Profile 50x100 D17VS/D17VS, specify length $\geq 80\text{mm} \leq 6000\text{mm}$		3 842 993 170/ __mm

Please contact your distributor for other machining options.

Section 2: Profiles

50x150 

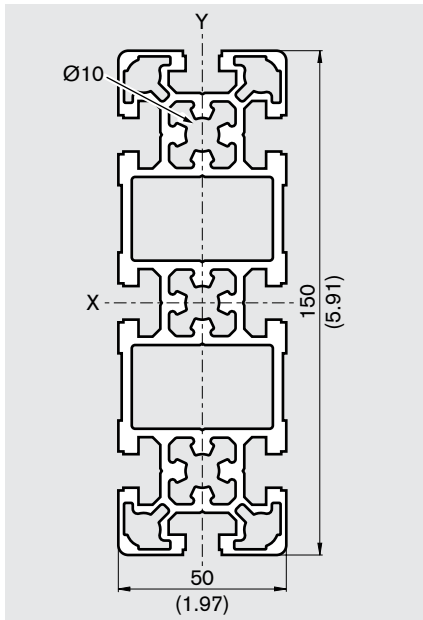





Features:

- Extra heavy-duty profile for applications where high strength and rigidity is needed
- Has eight 10mm T-slots

Non-Machined End Finish Options

	Part Number
Profile 50x150, pkg. of 4, 6000mm long	3 842 537 826
Profile 50x150, single, 6000mm long	3 842 529 378

Machined Options

	End Finish	Part Number
Profile 50x150 -/-, specify length $\geq 30\text{mm} \leq 6000\text{mm}$		3 842 993 196/ __mm
Profile 50x150 M12/-, specify length $\geq 55\text{mm} \leq 6000\text{mm}$		3 842 993 194/ __mm
Profile 50x150 M12/M12, specify length $\geq 110\text{mm} \leq 6000\text{mm}$		3 842 993 199/ __mm
Profile 50x150 D17/D17, specify length $\geq 80\text{mm} \leq 6000\text{mm}$		3 842 993 200/ __mm
Profile 50x150 D17VS/D17VS, specify length $\geq 80\text{mm} \leq 6000\text{mm}$		3 842 993 228/ __mm

Please contact your distributor for other machining options.

Design Engineering Tip

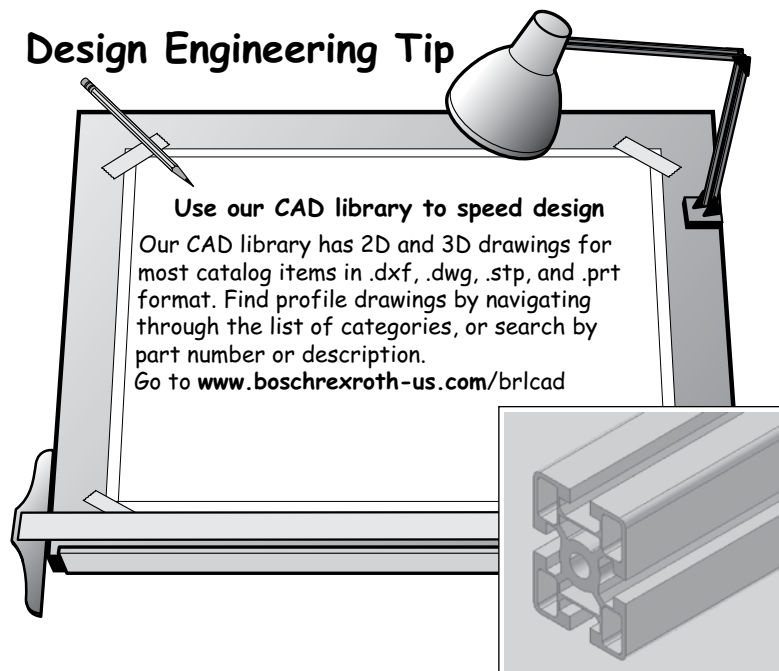

Section 2: Profiles

60-Series Profiles

2

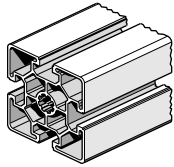

60x60
2-43

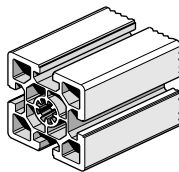

60x60H
2-44

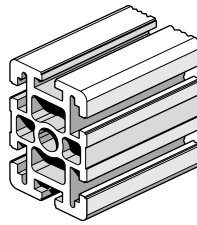

60x90H
2-45

60x60

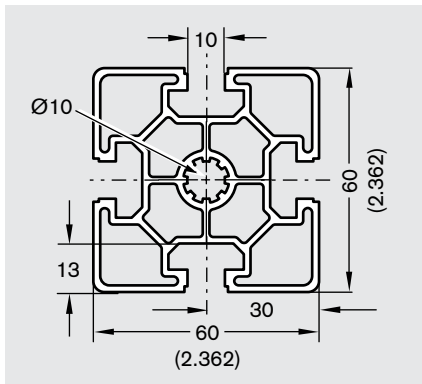

Features:

- General purpose profile suitable for medium-duty and heavy-duty applications
- Has four 10mm T-slots

Non-Machined End Finish Options

Part Number

- Profile 60x60, pkg. of 20, 5600mm long
- Profile 60x60, single, 5600mm long

- 3 842 511 872**
- 3 842 511 871**

Machined Options

End Finish

Part Number

- Profile 60x60, -/-, specify length $\geq 50\text{mm} \leq 5600\text{mm}$
- Profile 60x60, M12/-, specify length $\geq 55\text{mm} \leq 5600\text{mm}$
- Profile 60x60, D17/-, specify length $\geq 40\text{mm} \leq 5600\text{mm}$
- Profile 60x60, M12/M12, specify length $\geq 110\text{mm} \leq 5600\text{mm}$
- Profile 60x60, M12/D17, specify length $\geq 90\text{mm} \leq 5600\text{mm}$
- Profile 60x60, D17/D17, specify length $\geq 80\text{mm} \leq 5600\text{mm}$
- Profile 60x60, D17/D17VS, specify length $\geq 80\text{mm} \leq 5600\text{mm}$



3 842 992 443/ _mm



3 842 992 444/ _mm



3 842 992 449/ _mm



3 842 992 445/ _mm



3 842 992 446/ _mm



3 842 992 447/ _mm



3 842 992 448/ _mm

Please contact your distributor for other machining options.

Section 2: Profiles

60-Series Profiles

60x60H

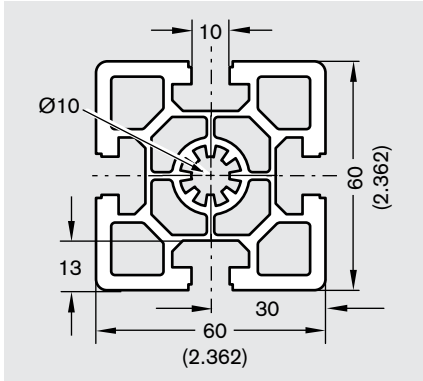











Features:

- General purpose profile suitable for medium-duty and heavy-duty applications
- Has four 10mm T-slots

Non-Machined End Finish Options

	Part Number
Profile 60x60H, pkg. of 20, 6000mm long	3 842 315 126
Profile 60x60H, single, 6000mm long	3 842 507 716

Machined Options

	End Finish	Part Number
Profile 60x60H, -/-, specify length $\geq 50\text{mm} \leq 6000\text{mm}$		3 842 990 350/ __mm
Profile 60x60H, M12/-, specify length $\geq 55\text{mm} \leq 6000\text{mm}$		3 842 990 351/ __mm
Profile 60x60H, M16/-, specify length $120\text{mm} \leq 6000\text{mm}$		3 842 990 352/ __mm
Profile 60x60H, D17/-, specify length $\geq 40\text{mm} \leq 6000\text{mm}$		3 842 990 370/ __mm
Profile 60x60H, M12/M12, specify length $\geq 110\text{mm} \leq 6000\text{mm}$		3 842 990 353/ __mm
Profile 60x60H, M16/M12, specify length $\geq 175\text{mm} \leq 6000\text{mm}$		3 842 990 354/ __mm
Profile 60x60H, M12/D17, specify length $\geq 90\text{mm} \leq 6000\text{mm}$		3 842 990 355/ __mm
Profile 60x60H, M16/D17, specify length $\geq 165\text{mm} \leq 6000\text{mm}$		3 842 990 373/ __mm
Profile 60x60H, D17/D17, specify length $\geq 80\text{mm} \leq 6000\text{mm}$		3 842 990 357/ __mm
Profile 60x60H, D17/D17VS, specify length $\geq 80\text{mm} \leq 6000\text{mm}$		3 842 990 359/ __mm

Please contact your distributor for other machining options.

Section 2: Profiles

2

60x90H 

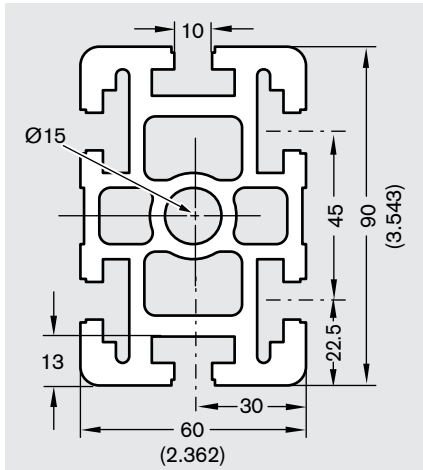















Features:

- For heavy-duty applications such as heavy-duty supports, cantilevered gantries, and conveyor rails
- Often used in linear motion applications
- Has six 10mm T-slots

Non-Machined End Finish Options

	Part Number
Profile 60x90H, pkg. of 10, 6000mm long	3 842 315 124
Profile 60x90H, single, 6000mm long	3 842 507 124

Machined Options

	End Finish	Part Number
Profile 60x90H, -/-, specify length $\geq 50\text{mm} \leq 6000\text{mm}$		3 842 990 450/ __mm
Profile 60x90H, M16/-, specify length $\geq 120\text{mm} \leq 6000\text{mm}$		3 842 990 453/ __mm
Profile 60x90H, D17/-, specify length $\geq 40\text{mm} \leq 6000\text{mm}$		3 842 990 095/ __mm
Profile 60x90H, D17VS/-, specify length $\geq 40\text{mm} \leq 6000\text{mm}$		3 842 990 096/ __mm
Profile 60x90H, M16/M16, specify length $\geq 240\text{mm} \leq 6000\text{mm}$		3 842 990 454/ __mm
Profile 60x90H, M16/F2, specify length $\geq 165\text{mm} \leq 6000\text{mm}$		3 842 990 472/ __mm
Profile 60x90H, M16/F1VS, specify length $\geq 165\text{mm} \leq 6000\text{mm}$		3 842 990 497/ __mm
Profile 60x90H, D17/D17, specify length $\geq 80\text{mm} \leq 6000\text{mm}$		3 842 990 097/ __mm
Profile 60x90H, D17/D17VS, specify length $\geq 80\text{mm} \leq 6000\text{mm}$		3 842 990 099/ __mm
Profile 60x90H, D17VS/D17VS, specify length $\geq 80\text{mm} \leq 6000\text{mm}$		3 842 990 098/ __mm
Profile 60x90H, F1/F1, specify length $\geq 110\text{mm} \leq 6000\text{mm}$		3 842 990 464/ __mm
Profile 60x90H, F2/F2, specify length $\geq 110\text{mm} \leq 6000\text{mm}$		3 842 990 478/ __mm
Profile 60x90H, F1VS/F1VS, specify length $\geq 110\text{mm} \leq 6000\text{mm}$		3 842 990 487/ __mm
Profile 60x90H, F1VS/F1, specify length $\geq 110\text{mm} \leq 6000\text{mm}$		3 842 990 481/ __mm

Please contact your distributor for other machining options.

Section 2: Profiles

80-Series Profiles

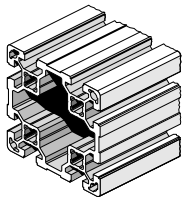

80x80
2-46

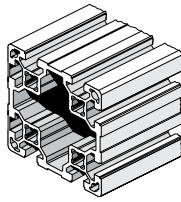

80x80 6S
2-47

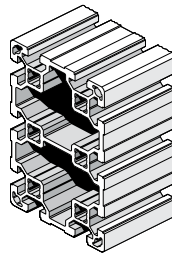

80x120
2-47

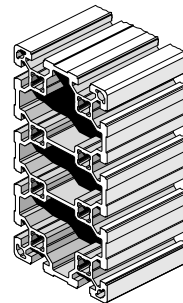

80x160
2-48

80x80

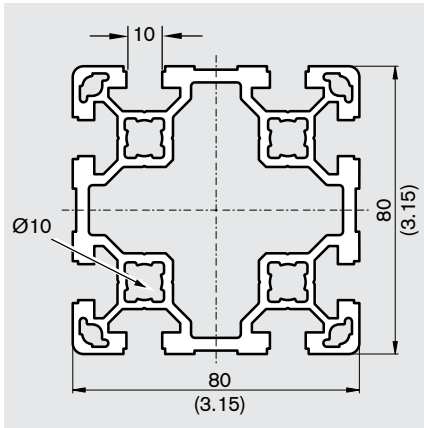

Features:

- Ideal for heavy-duty applications where added strength and additional T-slots are a must
- Has 8 10mm T-slots

Non-Machined End Finish Options	Part Number
Profile 80x80, pkg. of 6, 6000mm long	3 842 529 347
Profile 80x80, single, 6000mm long	3 842 529 348

Machined Options	End Finish	Part Number
Profile 80x80, -/-, specify length $\geq 30\text{mm} \leq 6000\text{mm}$		3 842 993 133/ __mm
Profile 80x80, M12/-, specify length $\geq 55\text{mm} \leq 6000\text{mm}$		3 842 993 134/ __mm
Profile 80x80, D17/-, specify length $\geq 40\text{mm} \leq 6000\text{mm}$		3 842 993 149/ __mm
Profile 80x80, M12/M12, specify length $\geq 110\text{mm} \leq 6000\text{mm}$		3 842 993 147/ __mm
Profile 80x80, M12/D17, specify length $\geq 90\text{mm} \leq 6000\text{mm}$		3 842 993 148/ __mm
Profile 80x80, D17/D17, specify length $\geq 80\text{mm} \leq 6000\text{mm}$		3 842 993 150/ __mm
Profile 80x80, D17/D17VS, specify length $\geq 80\text{mm} \leq 6000\text{mm}$		3 842 993 151/ __mm

Please contact your distributor for other machining options.

Section 2: Profiles

2

80x80 6S 

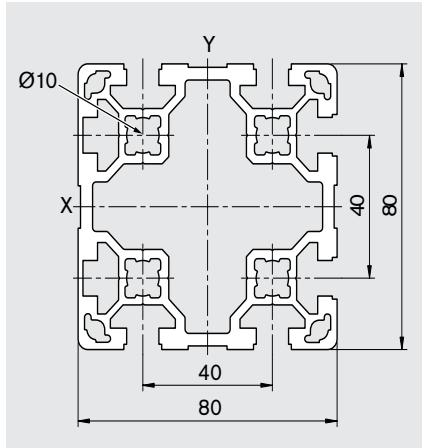

Features:

- Ideal for heavy-duty applications where added strength and additional T-slots are a must
- Has six 10mm T-slots

Non-Machined End Finish Options

- Profile 80x80 6S, pkg. of 6, 6000mm long
- Profile 80x80 6S, single, 6000mm long

Part Number

- 3 842 536 481**
- 3 842 536 482**

Machined Options

Profile 80x80 6S, -/-, specify length $\geq 40\text{mm} \leq 6000\text{mm}$

End Finish



Part Number

3 842 993 423/ __mm

Please contact your distributor for other machining options.

80x120 

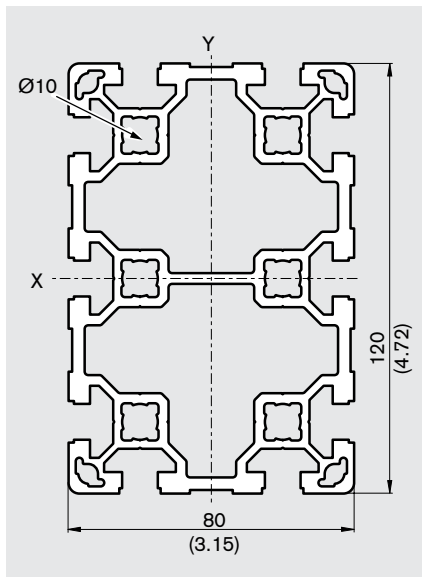

Features:

- Ideal for heavy-duty applications where added strength and additional T-slots are a must
- Has ten 10mm T-slots

Non-Machined End Finish Options

- Profile 80x120, pkg. of 4, 6000mm long
- Profile 80x120, single, 6000mm long

Part Number

- 3 842 537 828**
- 3 842 529 380**

Machined Options

Profile 80x120, -/-, specify length $\geq 30\text{mm} \leq 6000\text{mm}$

Profile 80x120, M12/-, specify length $\geq 55\text{mm} \leq 6000\text{mm}$

Profile 80x120, M12/M12, specify length $\geq 110\text{mm} \leq 6000\text{mm}$

Profile 80x120, D17/D17, specify length $\geq 80\text{mm} \leq 6000\text{mm}$

Profile 80x120, D17VS/D17VS, specify length $\geq 80\text{mm} \leq 6000\text{mm}$

End Finish



Part Number

- 3 842 993 201/ __mm**
- 3 842 993 202/ __mm**
- 3 842 993 203/ __mm**
- 3 842 993 204/ __mm**
- 3 842 993 229/ __mm**

Please contact your distributor for other machining options.

Section 2: Profiles

80-Series Profiles

80x160

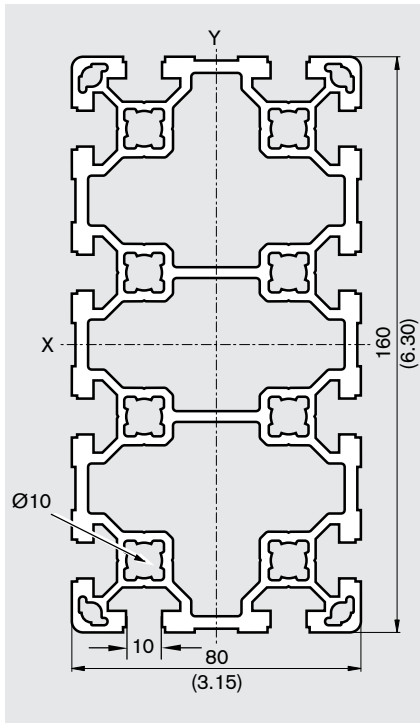

Features:

- Ideal for heavy-duty applications where added strength and additional T-slots are a must
- Has twelve 10mm T-slots







Non-Machined End Finish Options

- Profile 80x160, pkg. of 3, 6000mm long
- Profile 80x160, single, 6000mm long

Part Number

- 3 842 529 349**
- 3 842 529 350**

Machined Options

Machined Options	End Finish	Part Number
Profile 80x160, -/-, specify length $\geq 30\text{mm} \leq 6000\text{mm}$		3 842 993 127/ __mm
Profile 80x160, M12/-, specify length $\geq 55\text{mm} \leq 6000\text{mm}$		3 842 993 128/ __mm
Profile 80x160, D17/-, specify length $\geq 40\text{mm} \leq 6000\text{mm}$		3 842 993 154/ __mm
Profile 80x160, M12/M12, specify length $\geq 110\text{mm} \leq 6000\text{mm}$		3 842 993 152/ __mm
Profile 80x160, M12/D17, specify length $\geq 90\text{mm} \leq 6000\text{mm}$		3 842 993 153/ __mm
Profile 80x160, D17/D17, specify length $\geq 80\text{mm} \leq 6000\text{mm}$		3 842 993 155/ __mm
Profile 80x160, D17/D17VS, specify length $\geq 80\text{mm} \leq 6000\text{mm}$		3 842 993 226/ __mm

Please contact your distributor for other machining options.

Section 2: Profiles

90-Series Profiles

2

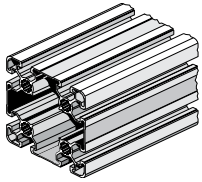

90x90 SL
2-49

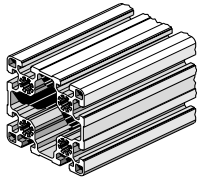

90x90
2-50

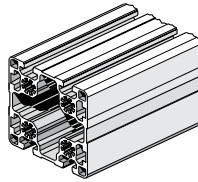

90x90 4S
2-50

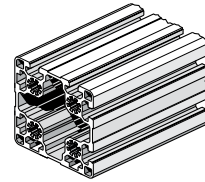

90x90 4VS
2-51

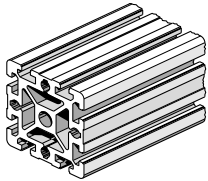

90x90H
2-51

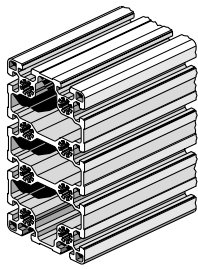

90x180
2-52

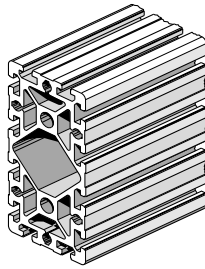

90x180H
2-53

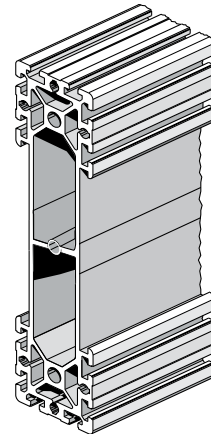

90x360H
2-54

90x90 SL 

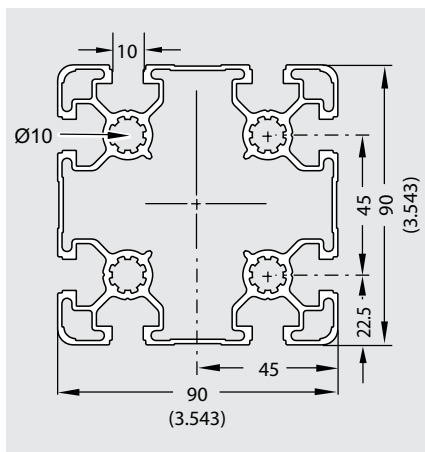

Features:

- Ideal for applications where reducing weight and additional T-slots are a must.
- Has eight 10mm T-slots

Non-Machined End Finish Options

Profile 90x90 SL, pkg. of 6, 6000mm long	3 842 537 100
Profile 90x90 SL, single, 6000mm long	3 842 537 101

Part Number

Machined Options

Profile 90x90, -/-, specify length $\geq 50\text{mm} \leq 6000\text{mm}$

End Finish



Part Number

3 842 993 449/ __mm

Please contact your distributor for other machining options.

Section 2: Profiles

90-Series Profiles

90x90 ¹⁰ GoTo

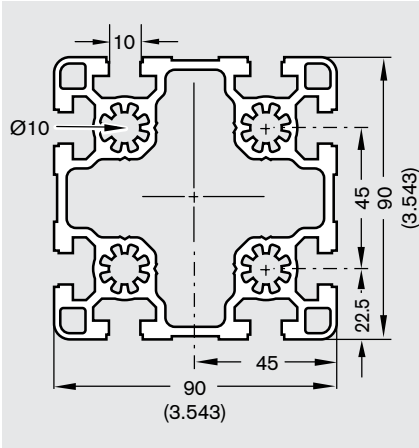

Features:

- Ideal for heavy-duty applications where added strength and additional T-slots are a must
- Center area can be used as a conduit for air lines, or as a pressurized air manifold
- Has eight 10mm T-slots

Non-Machined End Finish Options

Non-Machined End Finish Options	Part Number
Profile 90x90, pkg. of 6, 5600mm mm long	3 842 509 658 <i>GoTo</i>
Profile 90x90, single, 5600mm mm long	3 842 509 659 <i>GoTo</i>

Machined Options

Machined Options	End Finish	Part Number
Profile 90x90, -/-, specify length $\geq 50\text{mm} \leq 5600\text{mm}$		3 842 992 415/ __mm
Profile 90x90, M12/-, specify length $\geq 55\text{mm} \leq 5600\text{mm}$		3 842 992 416/ __mm
Profile 90x90, D17/-, specify length $\geq 40\text{mm} \leq 5600\text{mm}$		3 842 992 417/ __mm
Profile 90x90, M12/M12, specify length $\geq 110\text{mm} \leq 5600\text{mm}$		3 842 992 422/ __mm
Profile 90x90, M12/D17, specify length $\geq 90\text{mm} \leq 5600\text{mm}$		3 842 992 423/ __mm
Profile 90x90, M12/D17LF, specify length $\geq 90\text{mm} \leq 5600\text{mm}$		3 842 992 419/ __mm
Profile 90x90, D17/D17, specify length $\geq 80\text{mm} \leq 5600\text{mm}$		3 842 992 420/ __mm
Profile 90x90, D17/D17VS, specify length $\geq 80\text{mm} \leq 5600\text{mm}$		3 842 992 421/ __mm
Profile 90x90, D17LF/D17LF, specify length $\geq 80\text{mm} \leq 5600\text{mm}$		3 842 992 418/ __mm

Please contact your distributor for other machining options.

90x90 4S ¹⁰

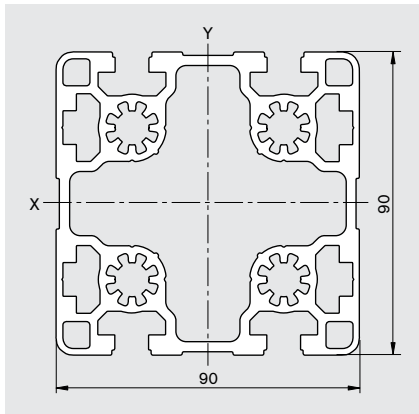

Features:

- Ideal for applications where smooth sides are required.
- Has four 10mm T-slots

Non-Machined End Finish Options

Non-Machined End Finish Options	Part Number
Profile 90x90 4S, pkg. of 6, 6000mm long	3 842 538 297
Profile 90x90 4S, single, 6000mm long	3 842 538 301

Machined Options

Machined Options	End Finish	Part Number
Profile 90x90 4S, -/-, specify length $\geq 50\text{mm} \leq 6000\text{mm}$		3 842 993 628/ __mm

Please contact your distributor for other machining options.



Section 2: Profiles

90x90 4VS ¹⁰

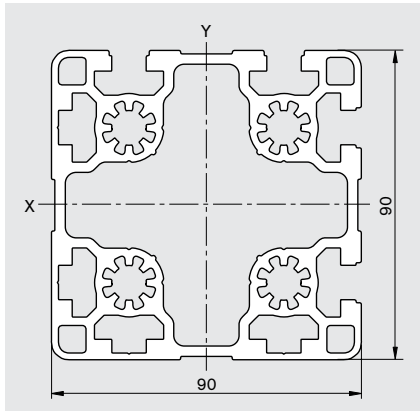

Features:

- Ideal for applications where smooth sides are required.
- Has four 10mm T-slots

Non-Machined End Finish Options

	Part Number
Profile 90x90 4VS, pkg. of 6, 6000mm long	3 842 538 296
Profile 90x90 4VS, single, 6000mm long	3 842 538 300

Machined Options

	End Finish	Part Number
Profile 90x90 4VS, -/-, specify length $\geq 50\text{mm} \leq 6000\text{mm}$	<input type="checkbox"/>	3 842 993 621/ __mm

Please contact your distributor for other machining options.

90x90H ¹⁰

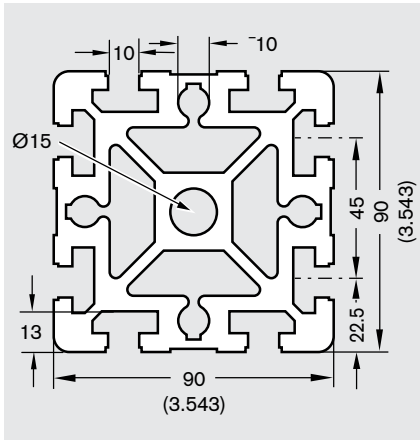

Features:

- Ideal for heavy-duty applications where added strength and additional T-slots are a must
- Has eight 10mm T-slots

Non-Machined End Finish Options

	Part Number
Profile 90x90H, pkg. of 6, 6000mm long	3 842 315 125
Profile 90x90H, single, 6000mm long	3 842 507 715

Machined Options

	End Finish	Part Number
Profile 90x90H, -/-, specify length $\geq 50\text{mm} \leq 6000\text{mm}$	<input type="checkbox"/>	3 842 990 500/ __mm
Profile 90x90H, M16/-, specify length $\geq 120\text{mm} \leq 6000\text{mm}$	<input type="checkbox"/>	3 842 990 501/ __mm
Profile 90x90H, M16-D22/-, specify length $\geq 120\text{mm} \leq 6000\text{mm}$	<input type="checkbox"/>	3 842 992 373/ __mm
Profile 90x90H, D17/-, specify length $\geq 40\text{mm} \leq 6000\text{mm}$	<input type="checkbox"/>	3 842 990 092/ __mm
Profile 90x90H, D17-D26/-, specify length $\geq 80\text{mm} \leq 6000\text{mm}$	<input type="checkbox"/>	8 981 992 294/ __mm
Profile 90x90H, D20-D31/-, specify length $\geq 95\text{mm} \leq 6000\text{mm}$	<input type="checkbox"/>	8 981 992 295/ __mm
Profile 90x90H, F2/-, specify length $\geq 55\text{mm} \leq 6000\text{mm}$	<input type="checkbox"/>	3 842 990 505/ __mm
Profile 90x90H, M16/M16, specify length $\geq 240\text{mm} \leq 6000\text{mm}$	<input type="checkbox"/>	3 842 990 502/ __mm
Profile 90x90H, M16/D17, specify length $\geq 160\text{mm} \leq 6000\text{mm}$	<input type="checkbox"/>	3 842 992 961/ __mm
Profile 90x90H, D17/D17, specify length $\geq 80\text{mm} \leq 6000\text{mm}$	<input type="checkbox"/>	3 842 990 093/ __mm
Profile 90x90H, D17/D17VS, specify length $\geq 80\text{mm} \leq 6000\text{mm}$	<input type="checkbox"/>	3 842 990 094/ __mm
Profile 90x90H, D17/F2, specify length $\geq 95\text{mm} \leq 6000\text{mm}$	<input type="checkbox"/>	3 842 992 374/ __mm
Profile 90x90H, F2/F2, specify length $\geq 110\text{mm} \leq 6000\text{mm}$	<input type="checkbox"/>	3 842 990 507/ __mm
Profile 90x90H, M16-D22/M16-D22, specify length $\geq 240\text{mm} \leq 6000\text{mm}$	<input type="checkbox"/>	3 842 993 083/ __mm

Please contact your distributor for other machining options.

Section 2: Profiles

90-Series Profiles

90x180

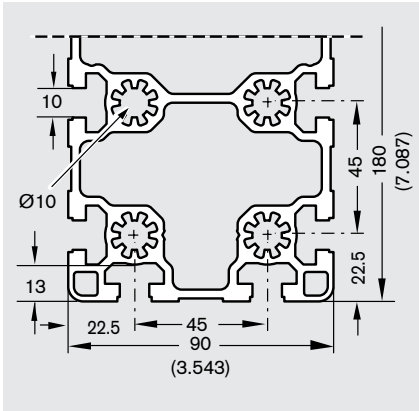

Features:

- Ideal for heavy-duty applications where added strength and additional T-slots are a must
- Center areas can be used as conduits for air lines, or as pressurized air manifolds
- Has twelve 10mm T-slots

End view of complete profile

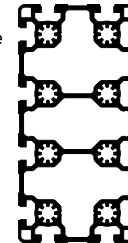









Non-Machined End Finish Options

- Profile 90x180, pkg. of 3, 5600mm long
- Profile 90x180, single, 5600mm long

Part Number

- 3 842 516 015**
- 3 842 516 014**

Machined Options

Machined Options	End Finish	Part Number
Profile 90x180, -/-, specify length $\geq 50\text{mm} \leq 5600\text{mm}$		3 842 992 857/ __mm
Profile 90x180, M12/-, specify length $\geq 55\text{mm} \leq 5600\text{mm}$		3 842 992 858/ __mm
Profile 90x180, M12/M12, specify length $\geq 110\text{mm} \leq 5600\text{mm}$		3 842 992 859/ __mm
Profile 90x180, M12/D17, specify length $\geq 90\text{mm} \leq 5600\text{mm}$		3 842 992 863/ __mm
Profile 90x180, M12/D17LF, specify length $\geq 90\text{mm} \leq 5600\text{mm}$		3 842 992 860/ __mm
Profile 90x180, D17/D17, specify length $\geq 80\text{mm} \leq 5600\text{mm}$		3 842 992 862/ __mm
Profile 90x180, D17LF/D17LF, specify length $\geq 80\text{mm} \leq 5600\text{mm}$		3 842 992 861/ __mm
Profile 90x180, D17VS/D17VS, specify length $\geq 80\text{mm} \leq 5600\text{mm}$		3 842 992 864/ __mm

Please contact your distributor for other machining options.

Section 2: Profiles

2

90x180H 

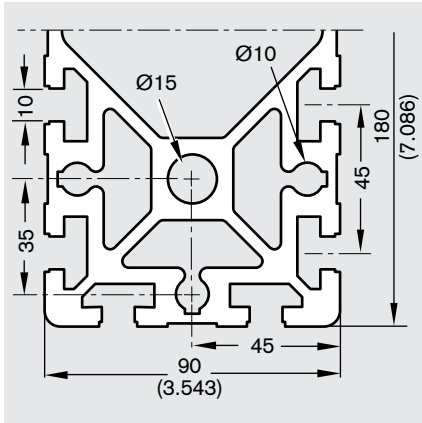

Features:

- Ideal for heavy-duty applications where added strength and additional T-slots are a must
- Center area can be used as a conduit for air lines, or as a pressurized air manifold
- Has twelve 10mm T-slots

End view of complete profile

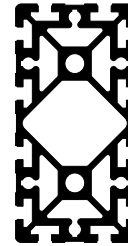









Non-Machined End Finish Options

- Profile 90x180H, pkg. of 3, 5600mm long
- Profile 90x180H, single, 5600mm long

Part Number

- 3 842 509 188**
- 3 842 509 203**

Machined Options

Machined Options	End Finish	Part Number
Profile 90x180H -/-, specify length $\geq 50\text{mm} \leq 5600\text{mm}$		3 842 990 416/ _mm
Profile 90x180H M16/-, specify length $\geq 120\text{mm} \leq 5600\text{mm}$		3 842 990 417/ _mm
Profile 90x180H M16-D22/-, specify length $\geq 120\text{mm} \leq 5600\text{mm}$		3 842 992 409/ _mm
Profile 90x180H M16/M16, specify length $\geq 240\text{mm} \leq 5600\text{mm}$		3 842 990 418/ _mm
Profile 90x180H M16/F2, specify length $\geq 180\text{mm} \leq 5600\text{mm}$		3 842 990 419/ _mm
Profile 90x180H D17LF/D17LF, specify length $\geq 80\text{mm} \leq 5600\text{mm}$		3 842 992 898/ _mm
Profile 90x180H D17LFS/D17LFS, specify length $\geq 80\text{mm} \leq 5600\text{mm}$		3 842 993 081/ _mm
Profile 90x180H D17VS/D17VS, specify length $\geq 80\text{mm} \leq 5600\text{mm}$		3 842 992 378/ _mm
Profile 90x180H F2/F2, specify length $\geq 110\text{mm} \leq 5600\text{mm}$		3 842 990 421/ _mm

Please contact your distributor for other machining options.

Section 2: Profiles

90-Series Profiles

90x360H

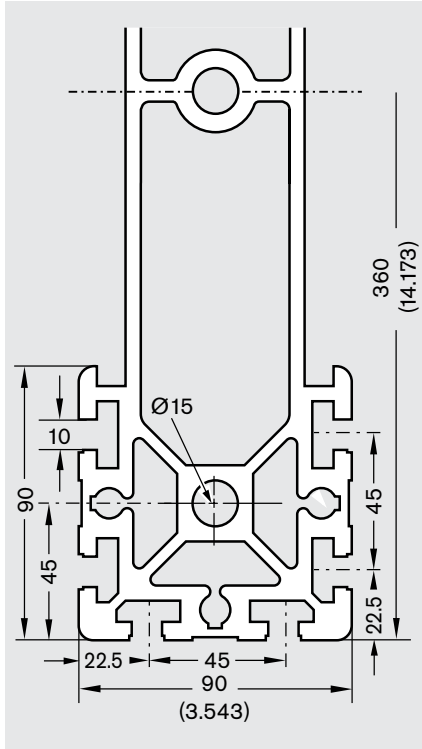

Features:

- Heaviest-duty profile available
- Typical applications include very heavy-duty machine frames where mass and strength are critical, cartesian/gantry robot frames, and very heavy-duty support columns
- Has twelve 10mm T-slots

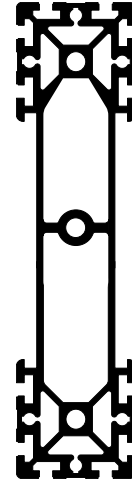

End view of complete profile



Machined Options

End Finish

Part Number

Profile 90x360H, -/-, specify length $\geq 50\text{mm} \leq 6000\text{mm}$		3 842 993 434/ __mm
Profile 90x360H, M16/M16, specify length $\geq 240\text{mm} \leq 6000\text{mm}$		3 842 993 435/ __mm
Profile 90x360H, F2/F2, specify length $\geq 110\text{mm} \leq 6000\text{mm}$		3 842 993 436/ __mm
Profile 90x360H, M16/-, specify length $\geq 240\text{mm} \leq 6000\text{mm}$		3 842 990 551/ __mm
Profile 90x360H, M16/D22, specify length $\geq 120\text{mm} \leq 6000\text{mm}$		3 842 992 379/ __mm
Profile 90x360H, M16-D22/M16-D22, specify length $\geq 240\text{mm} \leq 6000\text{mm}$		3 842 992 380/ __mm

Please contact your distributor for other machining options.

Section 2: Profiles

100-Series Profiles

2

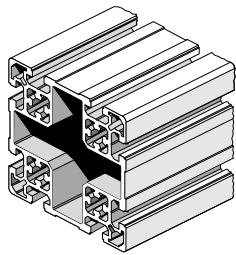

**100x100
2-55**

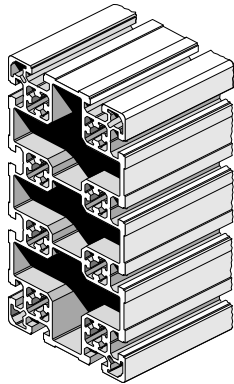

**100x200
2-56**

100x100

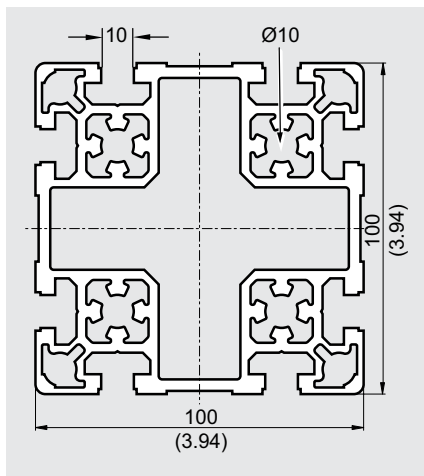

Features:

- Ideal for heavy-duty applications where added strength and additional T-slots are a must
- Has eight 10mm T-slots

Non-Machined End Finish Options

Profile 100x100, pkg. of 6, 6000mm long	3 842 529 355
Profile 100x100, single, 6000mm long	3 842 529 356

Part Number

Machined Options

Machined Options	End Finish	Part Number
Profile 100x100, -/-, specify length $\geq 30\text{mm} \leq 6000\text{mm}$		3 842 993 171/ __mm
Profile 100x100, M12/-, specify length $\geq 55\text{mm} \leq 6000\text{mm}$		3 842 993 172/ __mm
Profile 100x100, D17/-, specify length $\geq 40\text{mm} \leq 6000\text{mm}$		3 842 993 175/ __mm
Profile 100x100, M12/M12, specify length $\geq 110\text{mm} \leq 6000\text{mm}$		3 842 993 173/ __mm
Profile 100x100, M12/D17, specify length $\geq 90\text{mm} \leq 6000\text{mm}$		3 842 993 174/ __mm
Profile 100x100, D17/D17, specify length $\geq 80\text{mm} \leq 6000\text{mm}$		3 842 993 176/ __mm
Profile 100x100, D17/D17VS, specify length $\geq 80\text{mm} \leq 6000\text{mm}$		3 842 993 177/ __mm

Please contact your distributor for other machining options.

Section 2: Profiles

100-Series Profiles

100x200

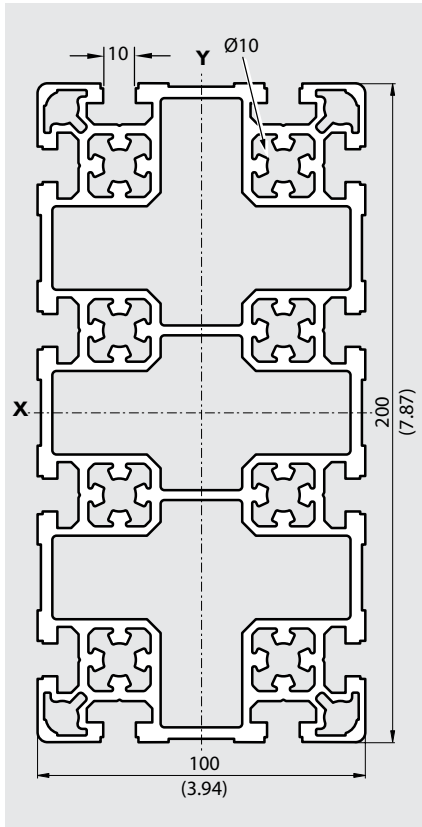

Features:

- Ideal for heavy-duty applications where added strength and additional T-slots are a must
- Has twelve 10mm T-slots

Non-Machined End Finish Options







Part Number

Profile 100x200, pkg. of 3, 6000mm long	3 842 529 357
Profile 100x200, single, 6000mm long	3 842 529 358

Machined Options

End Finish

Part Number

Profile 100x200, -/-, specify length $\geq 30\text{mm} \leq 6000\text{mm}$		3 842 993 178/ __mm
Profile 100x200, M12/-, specify length $\geq 55\text{mm} \leq 6000\text{mm}$		3 842 993 179/ __mm
Profile 100x200, D17/-, specify length $\geq 40\text{mm} \leq 6000\text{mm}$		3 842 993 182/ __mm
Profile 100x200, M12/M12, specify length $\geq 110\text{mm} \leq 6000\text{mm}$		3 842 993 180/ __mm
Profile 100x200, M12/D17, specify length $\geq 90\text{mm} \leq 6000\text{mm}$		3 842 993 181/ __mm
Profile 100x200, D17/D17, specify length $\geq 80\text{mm} \leq 6000\text{mm}$		3 842 993 183/ __mm
Profile 100x200, D17VS/D17VS, specify length $\geq 80\text{mm} \leq 6000\text{mm}$		3 842 993 227/ __mm

Please contact your distributor for other machining options.

Section 2: Profiles

Specialty Profiles

2

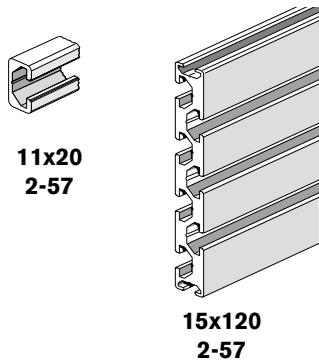

11x20
2-57

15x120
2-57

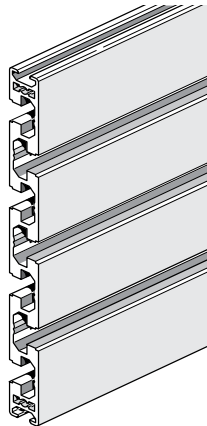

15x180
2-57



15x22.5
2-58

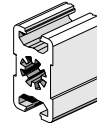

22.5x45
2-58

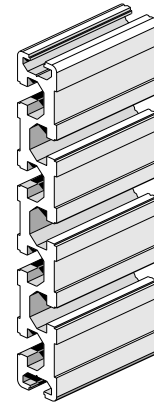

22.5x180
2-59

11x20

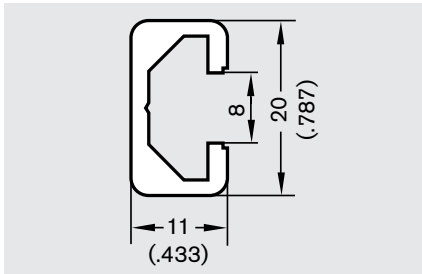

Features:

- Ideal for mounting lightweight components such as switch boxes, valves, and limit switches
- Use to construct economical, space-saving safety guard door frames
- Has one 8mm T-slot

Non-Machined End Finish Options

Profile 11x20, pkg. of 10, 2000mm long
Profile 11x20, single, 2000mm long

Part Number

3 842 513 581
3 842 513 582

Machined Options

Profile 11x20, -/-, specify length $\geq 30\text{mm} \leq 2000\text{mm}$	
Profile 11x20, D11/-, specify length $\geq 30\text{mm} \leq 2000\text{mm}$	
Profile 11x20, D11/D11, specify length $\geq 60\text{mm} \leq 2000\text{mm}$	

End Finish

Part Number

3 842 992 476/ __mm
3 842 992 477/ __mm
3 842 992 478/ __mm

Please contact your distributor for other machining options.

15x120

15x180

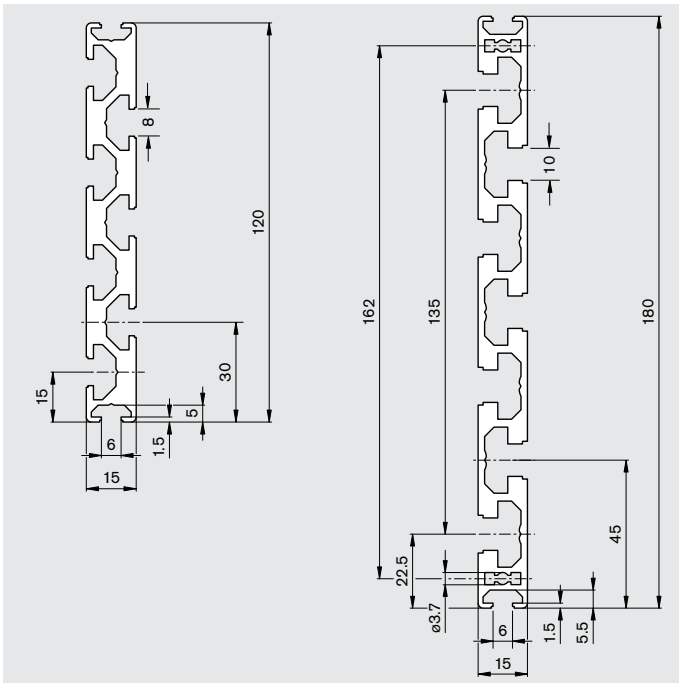

15x120

Non-Machined End Finish Options

Profile 15x120, pkg. of 10, 3000mm long
Profile 15x120, single, 3000mm long

Part Number

3 842 537 821
3 842 526 818

Machined Options

Profile 15x120, -/-, specify length $\geq 50\text{mm} \leq 3000\text{mm}$

Part Number

3 842 993 078/ __mm

Please contact your distributor for other machining options.

15x180

Non-Machined End Finish Options

Profile 15x180, pkg. of 6, 5600mm long
Profile 15x180, single, 5600mm long

Part Number

3 842 526 821
3 842 526 820

Machined Options

Profile 15x180, -/-, specify length $\geq 50\text{mm} \leq 5600\text{mm}$

Part Number

3 842 993 079/ __mm

Please contact your distributor for other machining options.

Section 2: Profiles

Specialty Profiles

15x22.5 ¹⁰

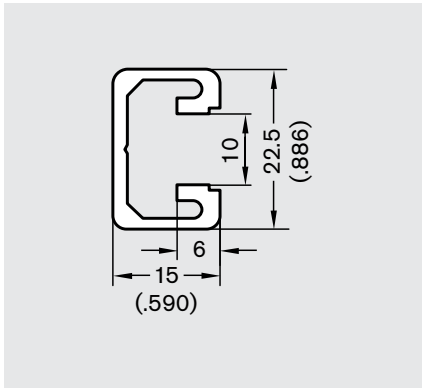

Features:

- Ideal for mounting light- to medium-weight components such as switch boxes, valves, and limit switches
- Use to construct economical, space-saving safety guard door frames
- Has one 10mm T-slot

Non-Machined End Finish Options	Part Number
Profile 15x22.5, pkg. of 10, 2000mm long	3 842 513 576
Profile 15x22.5, single, 2000mm long	3 842 513 577

Machined Options	End Finish	Part Number
Profile 15x22.5, -/-, specify length $\geq 30\text{mm} \leq 2000\text{mm}$		3 842 992 473/ __mm
Profile 15x22.5, D17/-, specify length $\geq 40\text{mm} \leq 2000\text{mm}$		3 842 992 474/ __mm
Profile 15x22.5, D17/D17, specify length $\geq 80\text{mm} \leq 2000\text{mm}$		3 842 992 475/ __mm

Please contact your distributor for other machining options.

22.5x45 ¹⁰

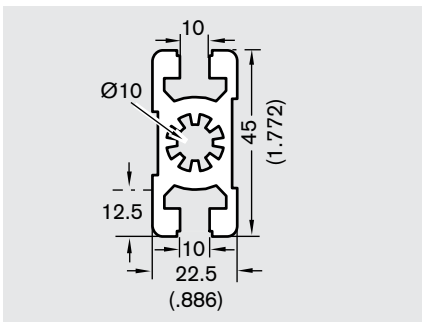

Features:

- Uses include rails and panel mounting in partitions
- Has two 10mm T-slots

Non-Machined End Finish Options	Part Number
Profile 22.5x45, pkg. of 24, 6000mm long	3 842 537 812
Profile 22.5x45, single, 6000mm long	3 842 502 695

Machined Options	End Finish	Part Number
Profile 22.5x45, -/-, specify length $\geq 30\text{mm} \leq 6000\text{mm}$		3 842 990 292/ __mm
Profile 22.5x45, M12/-, specify length $\geq 55\text{mm} \leq 6000\text{mm}$		3 842 990 087/ __mm
Profile 22.5x45, D17VS/-, specify length $\geq 40\text{mm} \leq 6000\text{mm}$		3 842 990 088/ __mm
Profile 22.5x45, M12/M12, specify length $\geq 110\text{mm} \leq 6000\text{mm}$		3 842 990 090/ __mm
Profile 22.5x45, M12/D17VS, specify length $\geq 90\text{mm} \leq 6000\text{mm}$		3 842 990 089/ __mm
Profile 22.5x45, D17VS/D17VS, specify length $\geq 80\text{mm} \leq 6000\text{mm}$		3 842 990 091/ __mm

Please contact your distributor for other machining options.

Section 2: Profiles

2

22.5x180 

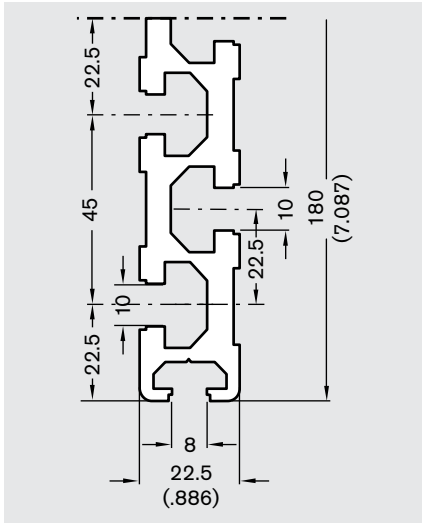

Features:

- Ideal for fixturing, end of arm tooling applications, and other applications requiring multiple T-slots
- Can be used as a carriage profile or bearing block header for linear motion applications
- Has seven 10mm T-slots on the long sides and an 8mm T-slot on each short side

Non-Machined End Finish Options

Part Number

Profile 22.5x180, pkg. of 6, 5600mm long

3 842 509 179

Profile 22.5x180, single, 5600mm long

3 842 509 206

Machined Options

End Finish

Part Number

Profile 22.5x180, -/-, specify length $\geq 50\text{mm} \leq 5600\text{mm}$



3 842 990 345/ __mm

Profile 22.5x180, D28/-, specify length $\geq 55\text{mm} \leq 5600\text{mm}$



3 842 990 346/ __mm

Profile 22.5x180, D28/D28, specify length $\geq 110\text{mm} \leq 5600\text{mm}$



3 842 990 347/ __mm

Please contact your distributor for other machining options.

Section 2: Profiles

Specialty Profiles

Bosch Rexroth offers a wide variety of other specialty profiles, specially designed for specific applications such as enclosures, guarding, conveyors, and linear motion. Some of the most popular types of specialty profiles are highlighted below.

Refer to the appropriate section of this catalog for additional information.

Aluminum Sliding Door Profiles

Special profiles can be used to create a variety of door styles, including sliding and overhead rolling doors. See Section 5, "Doors and Door Components" for these and other door profiles and hardware.

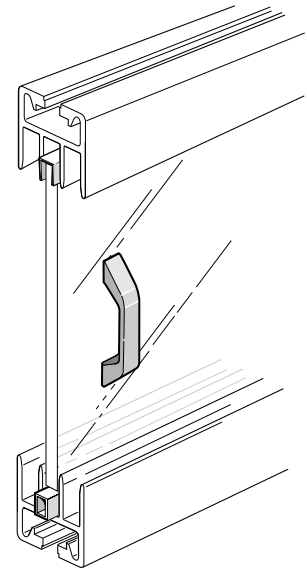
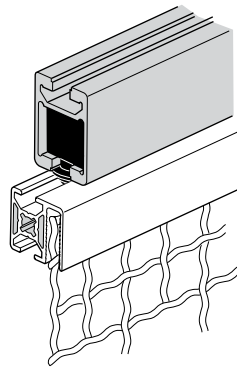

EcoSafe™ Guarding and Enclosures

Whether you are setting up perimeter guarding or a custom machine enclosure, Bosch Rexroth offers the profiles, connectors, and accessories you need. See Section 6, "EcoSafe Guarding and Machine/Safety Enclosures" for further details.

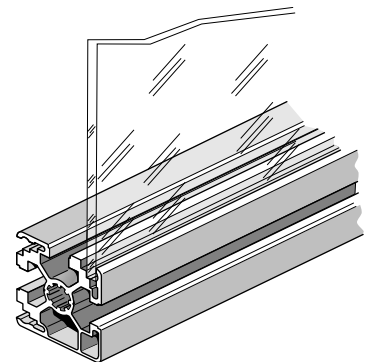
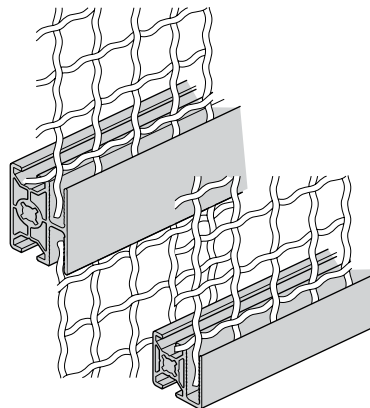

Section 2: Profiles

2

Fixture Plates, Tray Profiles, and Other Workstation Components

There are a variety of profiles and components available to create and customize workstations for virtually any task. From fixture plates to dispenser bins and overhead tool rails to work trays, Bosch Rexroth offers virtually endless possibilities. See Section 11, "Ergonomic Workplace Equipment".

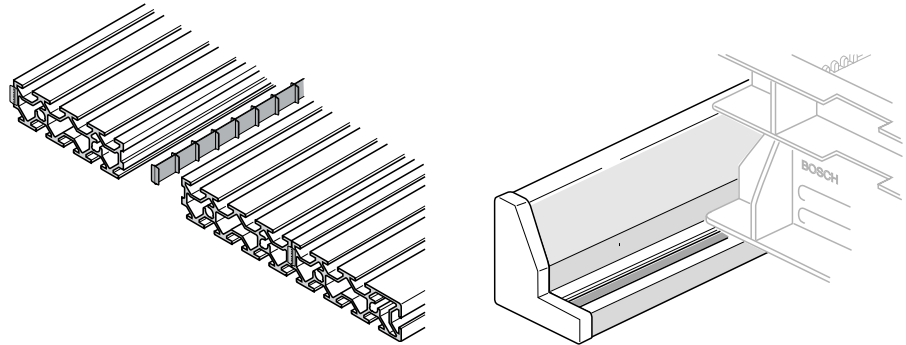
**EcoFlow™ Roller Profiles**

Transporting and positioning workpieces at and between workstations has never been easier, with a full range of profiles and accessories designed to maximize ergonomic workpiece flow.

See Section 10, "EcoFlow Conveyor and Transport Components".

